

Phoenix Fire Department

Fire Prevention

Emergency Access

Approved Details

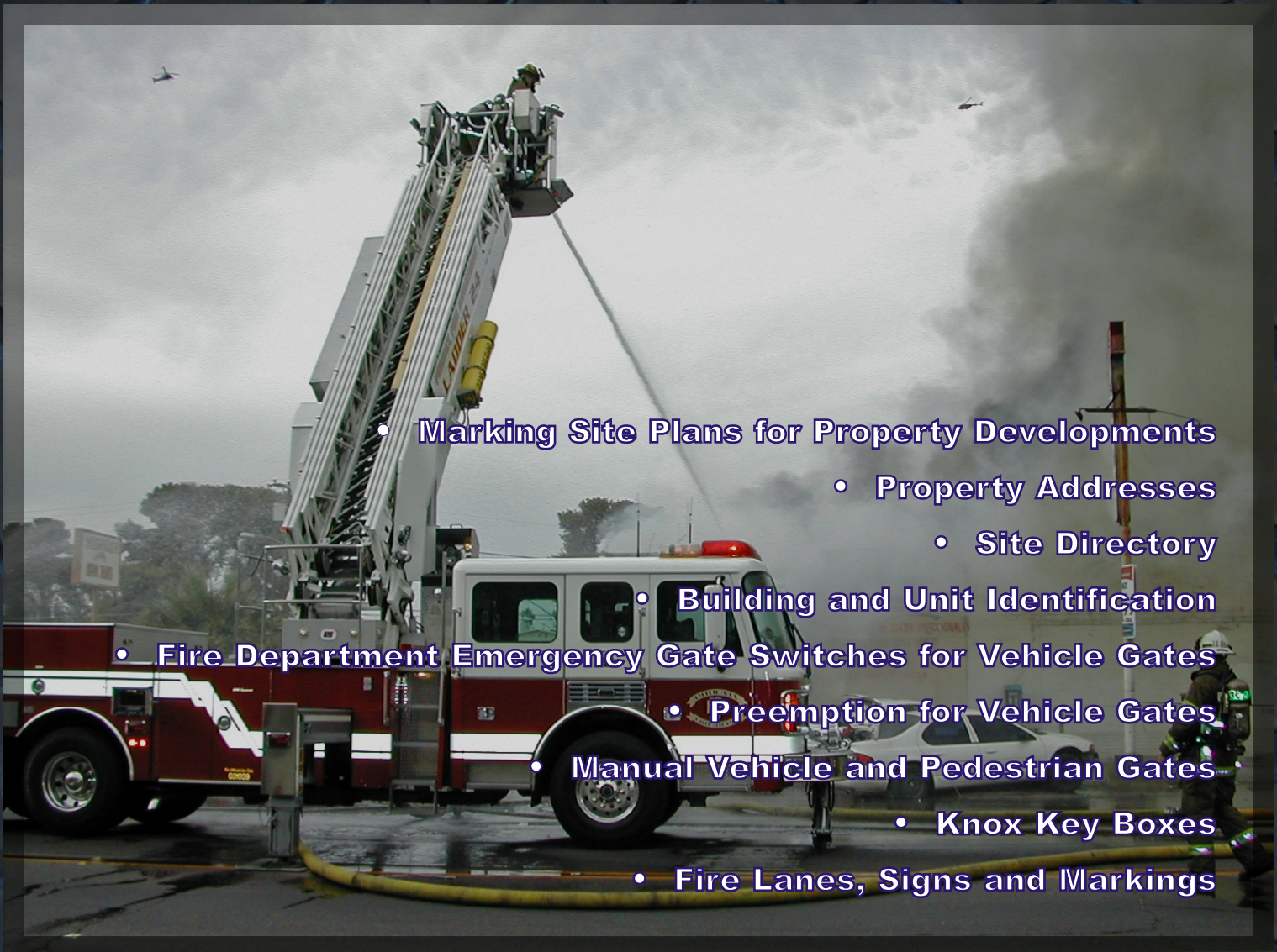

- Marking Site Plans for Property Developments
 - Property Addresses
 - Site Directory
- Building and Unit Identification
- Fire Department Emergency Gate Switches for Vehicle Gates
- Preemption for Vehicle Gates
- Manual Vehicle and Pedestrian Gates
- Knox Key Boxes
- Fire Lanes, Signs and Markings

REVISED JUNE 2008

Phoenix Fire Department At Work





Fire Department Emergency Access

It is essential that emergency response personnel have unimpeded access to fires and medical incidents. In the event of a fire or life threatening medical emergency, fire personnel must be able to reach the scene as quickly as possible. In a true emergency, a few seconds can literally mean the difference between life and death. How quickly crews can begin fighting a fire will often determine how successful they are in stopping the fire and preventing further damage. Fire Code requirements pertaining to emergency access were written to facilitate the Fire Department's ability to quickly and safely respond to all occupancies in the City. Your compliance with these requirements will help us to better help you in the event of an emergency.

The Phoenix Fire Department has put this book together to assist you in complying with Fire Department emergency access requirements. The enclosed diagrams and drawings provide the approved details for parking and access of fire apparatus. It also includes guidelines for compliance with handicapped parking laws. The Fire Department hopes that this information will help you to understand Fire Code requirements and our emergency access needs.

If you have any questions or if you need help with access requirements, please call Phoenix Fire Prevention Access Officers at 602-256-3382 or 602-262-6771.



This book has been developed to make it easy for commercial and residential property owners, architects, builders, gate companies, sign companies and others to fully understand the emergency access gate and other access requirements of the Phoenix Fire Department and Fire Code.

It is reviewed and updated regularly so that those who need and use it have the latest information available to them. In addition, it has been placed on a CD-ROM for those who find it more convenient to use it electronically.

Many people in the Fire Department have helped with the development and continued improvement of this book. Seven people stand out for their exceptional work and continued support.

They are:

- Richard Tritch, Emergency Access Officer, was the visionary behind this project. He came up with the plans, initiated the Fire Code changes and enforcement, and became the Fire Department's liaison for all of the companies and agencies involved in the project. These procedures make properties safer for their occupants.
- Barbara Koffron, Fire Marshal and a 30+ year member of the Fire Department, oversees the Fire Prevention Division, which includes the Emergency Access Division. Without her strong support, this book and many of the Fire Department's emergency access programs would not be possible.
- Linda Hertz, a Senior Drafting Technician in the Mapping Section of the Fire Department. She has worked on emergency access programs for more than seven years and is responsible for the diagrams and technical drawings contained in this book. Her knowledge and skills have helped take much of the guesswork out of the emergency access requirements.
- Roger Ulrich and Brett Archer. As Fire Prevention Specialists in the Access Section, they were instrumental in developing this book and organizing the information contained within it. Even though they have both become Fire Fighters, they continue to support the Emergency Access Program.
- Tim Kreis, formerly a Fire Prevention Specialist in the Access Section, now a firefighter, continues to support the Emergency Access program. Tim has worked diligently to assure that as we move to a new fire code all of the City's Emergency Access needs are addressed.
- Nicole Munson, who has provided invaluable assistance in drafting, editing and formatting this book. Her technical skills, coupled with her positive can-do attitude have made this project easier and more pleasant for all involved.



EMERGENCY ACCESS SECTION

EMERGENCY ACCESS OFFICER:

RICHARD TRITCH

PHONE: 602-256-3382 (DESK)
602-316-6147 (CELL)

E-MAIL: RICHARD.TRITCH@PHOENIX.GOV

SUPERVISOR FOR EMERGENCY ACCESS SECTION / PROGRAM MANAGER

CITY WIDE EMERGENCY ACCESS GATE INSPECTOR

PHONE: 602-262-6771

PLAN REVIEW FOR ALL VEHICLE ACCESS GATES, INCLUDING OTHER VEHICLE BARRIERS (BOLLARDS, CONTROL ARMS, ROLL UP DOORS, ETC.) ALL FIELD INSPECTIONS FOR VEHICLE ACCESS GATES AND CAPTAIN'S ACCESS SERVICE REQUESTS.

CITY WIDE EMERGENCY ACCESS INSPECTOR

PHONE: 602-262-6771

EMERGENCY ACCESS REGULATIONS INCLUDING, FIRE LANING, (ALTERNATIVE SURFACE FIRE LANING), *KNOX BOXES*, BUILDING ADDRESSING AND NUMBERING, FIRE PROTECTION SIGNAGE, DIRECTIONAL SIGNAGE, SITE DIRECTORIES AND CAPTAIN'S ACCESS SERVICE REQUESTS.

POOL ABATEMENT INSPECTOR

PHONE: 602-262-6771

POOL ABATEMENT CALLS (PERFORMS NO PHYSICAL TASK THAT MAY AGGRAVATE OR RE-INJURE EMPLOYEE. ALL KNOX BOX SERVICE REQUESTS, NEW CONSTRUCTION, EXISTING BUILDINGS, RESIDENTIAL HOMES.

NOTE: CUSTOMER SERVICE IS OUR FIRST PRIORITY; IF YOU FEEL YOU NEED TO DO A QUICK INFORMAL PLAN REVIEW PLEASE GIVE US A CALL. OUR GOAL AS A SECTION IS TO DELIVER CUSTOMER SATISFACTION.

INFORMAL PLAN REVIEWS AVAILABLE
MONDAY-FRIDAY 7:30-8:30 A.M. CALL FOR AN APPOINTMENT



MINIMUM ACCESS REQUIREMENTS FOR NEW CONSTRUCTION SITES WITH COMBUSTIBLES ON-SITE

Early Construction Phase

1. Provide the Fire Department with a site address located adjacent to a main entrance
 - Must include name of property and 12" x 2" minimum address numbers
2. All hydrants must be in service and accessible for Fire Department use at all times and prior to combustibles being stocked on site
3. Hydrants shall be located so that they are not more than 350 feet from all combustible construction. Distance is measured as the truck travels, not line of sight.
4. Maintain a Fire Department approved access road to all buildings during construction and when any combustibles are on site. Access road shall be within 150 feet of interior of building and shall be a minimum of 16 feet wide. If access road exceeds 200 feet in length, a turnaround is required.
 - A minimum of 6" of compacted AB material graded so that ponding does not occur after rainfall
 - Access Road must be maintained at all times during construction

CHAPTER 1

FIRE LANES

CONTENTS:

- **Fire Lane Signs And Installations**
- **Fire Lane Striping (Red Painted Curbs)**
- **Hydrant Access**
- **Alternative Fire Lane Markings**
- **Alternative Surface Fire Apparatus Roads**
- **Removable Bollards and Fire Lane Signs**

PURPOSE:

Proper fire laning directly effects how the Fire Department is able to maneuver through a property. These fire lane standards help to ensure unimpeded access for our fire apparatus.



STEPS TO OBTAIN EMERGENCY ACCESS PERMIT.

DO NOT SUBMIT 2 ENTIRE SETS OF BUILDING PLANS (see below for required pages)

- ❑ Bring **two** sets of **Emergency Access** plans to City Hall (200 W. Washington)
 - ❑ Take the **two** sets of plans to the **Fire Plan Review Office** 10th floor
 - ❑ Complete the plan review application
-

EMERGENCY ACCESS PLANS:

- ❑ Two sets of plans, drawn to scale
 - ❑ Plan submittal shall include; **site plan and building elevations** (all sides), and a dedicated page(s) including signage / addressing / Knox box(s) details and installation requirements. Additional drawings may be required depending on the scope of the project
 - ❑ Description of the proposed project (new build, remodel, etc.) and the business operation.
 - ❑ Owners name, mailing address, contact person, and phone number optional
-

THE FOLLOWING ARE SPECIFIC PLAN REQUIREMENTS:

- ❑ Architectural site plan that depicts all buildings, roadways, significant landscape features, fire hydrants, fire department connections, and water retention features
- ❑ Site plan shall also depict:
 1. Address number location(s)
 2. Building number location(s) (if applicable)
 3. Building spread plate location(s) (if applicable)
 4. Fire lane location and markings (i.e. red curb, fire lane signs, stencil of "No Parking Fire Lane" in front of ALL private hydrants, blue reflector in front of ALL hydrants) and Details of the required signage
 5. Knox Box type and location(s)
 6. Pedestrian gate location(s) (if applicable)

7. Rooms and/or areas containing fire protection equipment (fire riser room/cabinet, alarm panel, fire control room, fire pump room) and the appropriate signage to identify the fire protection equipment

8. Stairwells and Signage

- ❑ Site plans must also show orientation to streets, property line, and point of compass (North Arrow)



- ❑ Drawing must be to scale and include a graphic representation of the scale
- ❑ Drawing must be legible and dedicated to the specific item being reviewed

****Stamped approved plans, and permit must be on site for final inspection.**

APPROVED PHOENIX FIRE DEPARTMENT FIRE LANE SIGNS (FIGURE 5-4)

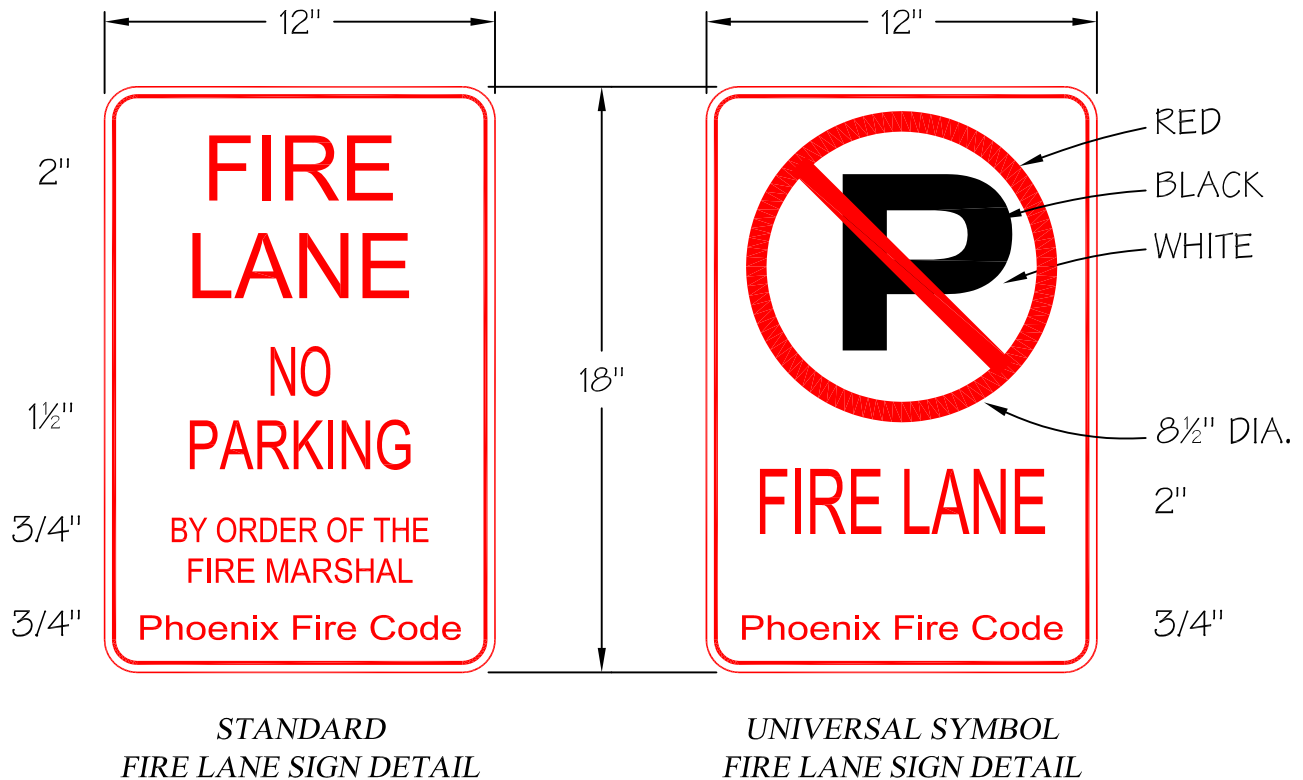

1. THE SIGN PLATE SHALL BE A MINIMUM OF 12" X 18" WITH A THICKNESS OF .080 ALUMINUM CONSTRUCTION.

2. THE SIGN FACE SHALL HAVE A WHITE REFLECTIVE BACKGROUND WITH A RED LEGEND. USE THE STANDARD 3M SCOTCHLITE SIGN FACE NUMBER R7-32 OR EQUIVALENT, WITH RED SCREEN PRINTED LETTERING AS SHOWN ABOVE.



APPROVED PHOENIX FIRE DEPARTMENT FIRE LANE SIGNS

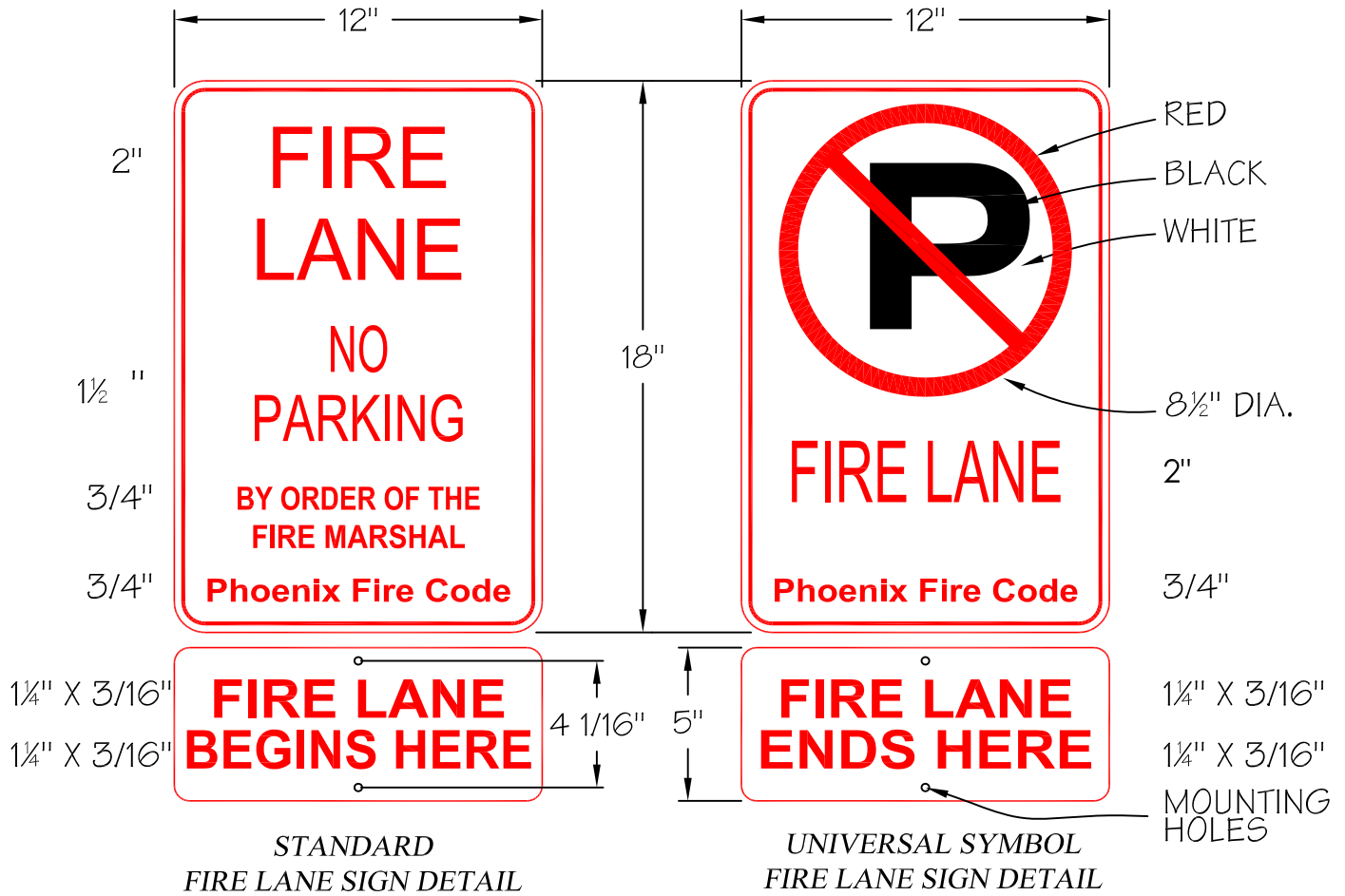

1. THE SIGN PLATE SHALL BE A MINIMUM OF 12" X 18" WITH A THICKNESS OF .080 ALUMINUM CONSTRUCTION.
2. THE SIGN FACE SHALL HAVE A WHITE REFLECTIVE BACKGROUND WITH A RED LEGEND. USE THE STANDARD 3M SCOTCHLITE SIGN FACE NUMBER R7-32 OR EQUIVALENT, WITH RED SCREEN PRINTED LETTERING AS SHOWN ABOVE.
3. SPECIAL APPLICATION DETAILS MUST BE PRE-APPROVED BY PFD-EMERGENCY ACCESS OFFICER AT 602-256-3382

SPECIAL APPLICATION

Click on thumbtack for
Auto CAD File



**PHOENIX
FIRE DEPARTMENT**

SPECIAL APPLICATION
FIRE LANE SIGNS

L. HERTZ DETAIL 1.2 JULY 2003

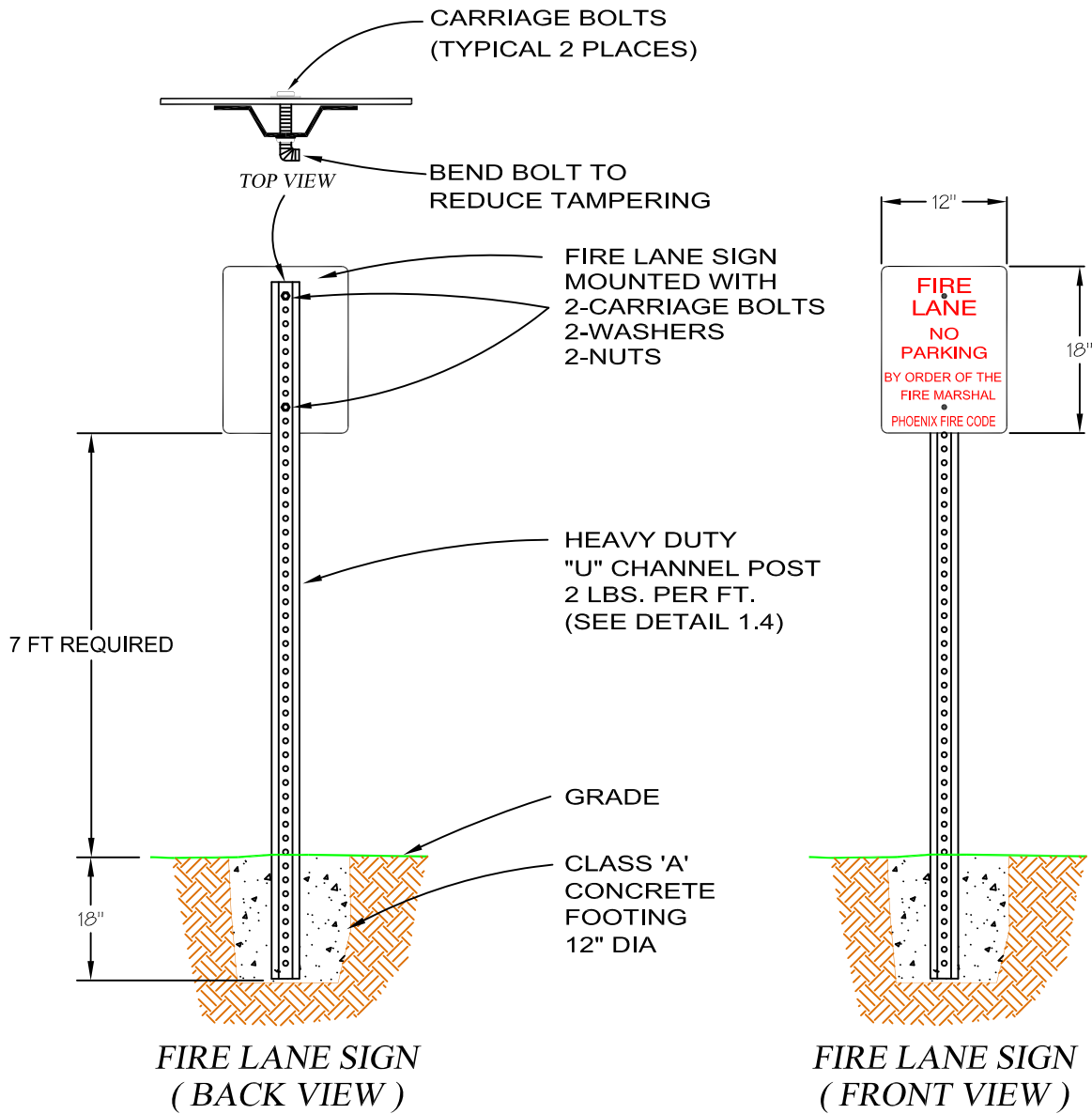

**RECOMMEND
THE FOLLOWING MATERIALS FOR INSTALLATION:**

10 FT LONG U-CHANNEL GALVANIZED OR PAINTED POST

FIRE SIGN (12" X 18") .080 ALUMINUM CONSTRUCTION WITH WHITE REFLECTIVE BACKGROUND AND RED SCREEN PRINTED LEGEND (SEE DETAIL 1.1)

1/4" BOLTS & NUTS LARGE FLAT OR FENDER WASHERS

SIGN MUST FACE THE ONCOMING TRAFFIC

POST SHALL BE INSTALLED 12" TO 18" FROM BACK OF CURB OR BACK OF SIDEWALK

FIRE DEPT. RECOMMENDS YOU BLUE STAKE BEFORE YOU DIG.

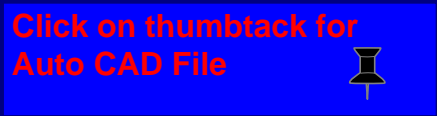

APPROVED FIRE LANE POSTS (FIGURE 5-5)

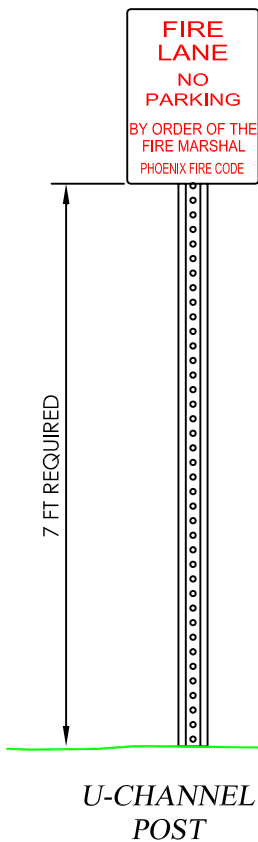
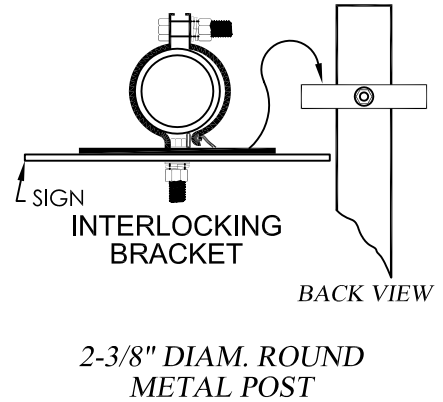
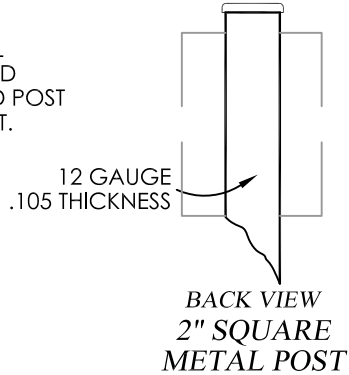
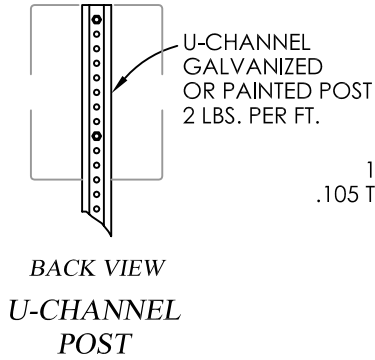
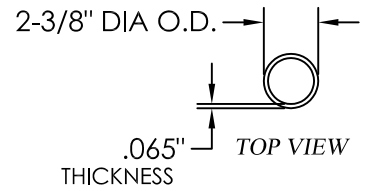
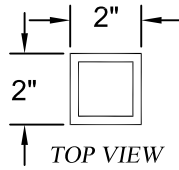
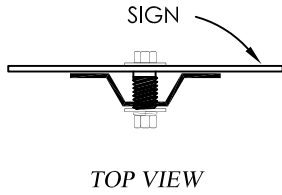

NOTES:

1. APPROVED SIGNS SHALL BE CONSTRUCTED OF .080 ALUMINUM WITH A REFLECTIVE BACKGROUND.
2. MINIMUM OF 1/4" BOLTS W/ FLAT WASHERS AND NUTS THAT BOLT THROUGH.
3. POST FOOTING SHALL BE 12" IN DIAM. AND 18" IN DEPTH.
4. THE SIGN SHALL BE LOCATED 7 FT FROM GRADE TO BOTTOM OF SIGN.
5. FIRE LANE SIGN SHALL BE INSTALLED 12" TO 18" FROM BACK OF CURB OR BACK OF SIDEWALK.
6. SIGNS MUST FACE THE ONCOMING TRAFFIC.





FNAME:PHOTOS_RU3.CDR
CALL FIRE PREVENTION-ACCESS OFFICER
FOR QUESTIONS OR ASSISTANCE
(602)256-3382 OR (602)262-6771

[Click on thumbtack for
Corel DRAW File](#) 



**FIRE DEPARTMENT
BUILDING NUMBER
UNIT SPREAD**

L. Hertz DP 1.1 AUG. 2003

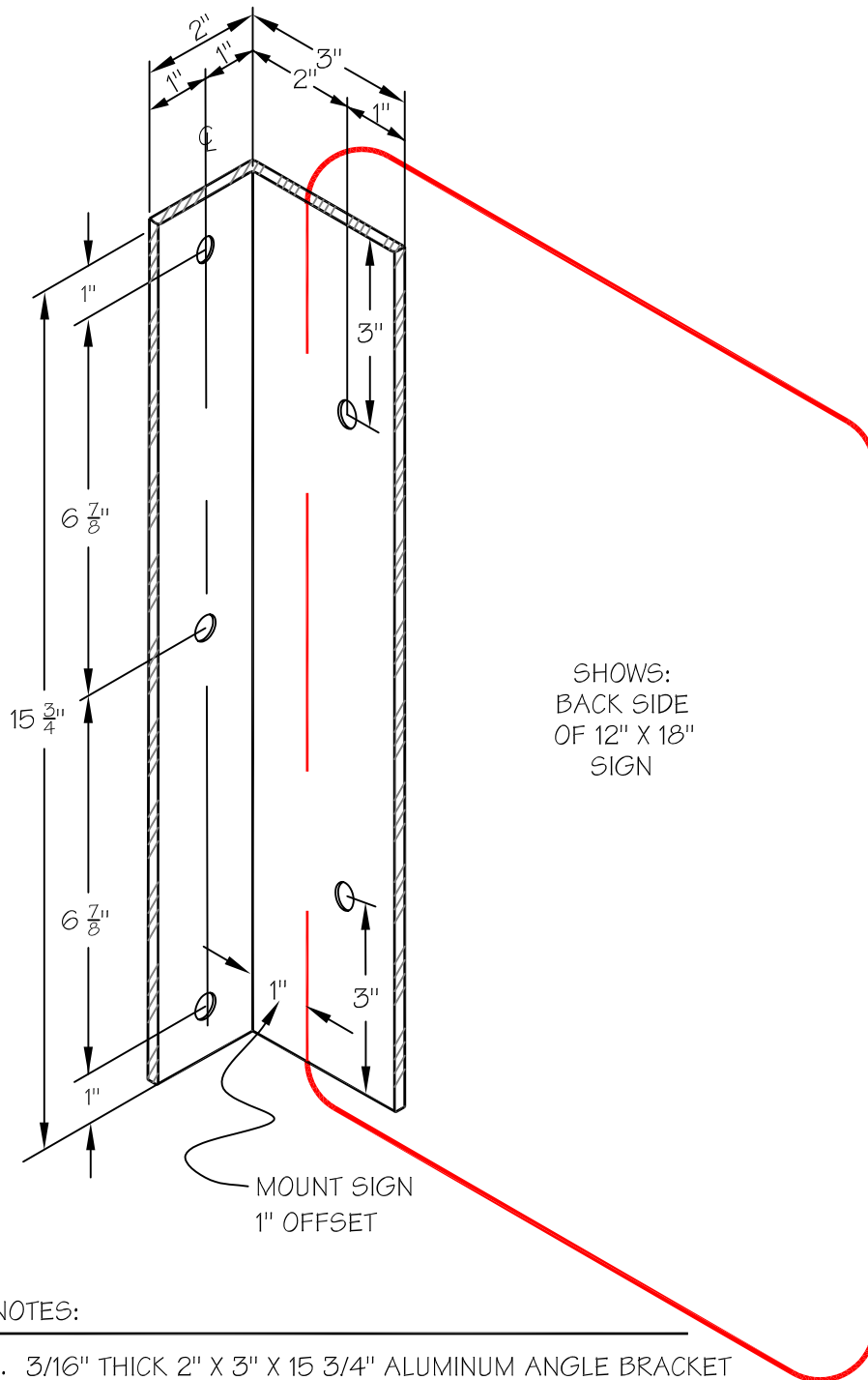

NOTES:

1. 3/16" THICK 2" X 3" X 15 3/4" ALUMINUM ANGLE BRACKET
2. THE SIGN PLATE SHALL BE A MINIMUM OF 12" X 18" WITH A THICKNESS OF .080 ALUMINUM CONSTRUCTION.
3. APPROVED SIGN BRACKET IS AVAILABLE FOR FLAG MOUNTED F.D. ACCESS SIGNS. BRACKET CAN BE USED ON EITHER THE RIGHT OR LEFT SIDE OF SIGN.
4. THIS APPLICATION ONLY AVAILABLE WHEN SIGN CANNOT BE INSTALLED ON AN APPROVED POST.
5. THIS APPLICATION MUST BE PRE-APPROVED BY FIRE PREVENTION ACCESS OFFICER.

FILE NAME: FSHyd_Wall_Bracket.dwg
CALL FIRE PREVENTION-ACCESS OFFICER
FOR QUESTIONS OR ASSISTANCE
602-256-3382 OR 602-262-6771

[Click on thumbtack for
Auto CAD File](#)



**PHOENIX
FIRE DEPARTMENT**

**WALL SIGN BRACKET
"FLAG MOUNT"**

L. HERTZ DETAIL 1.5 APRIL 2003

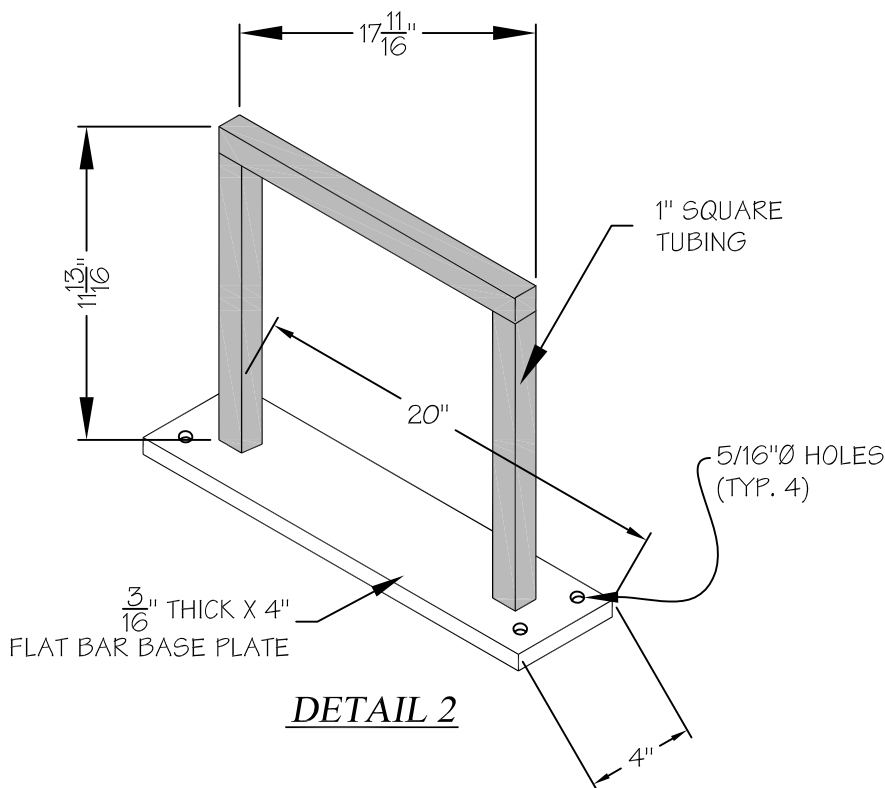
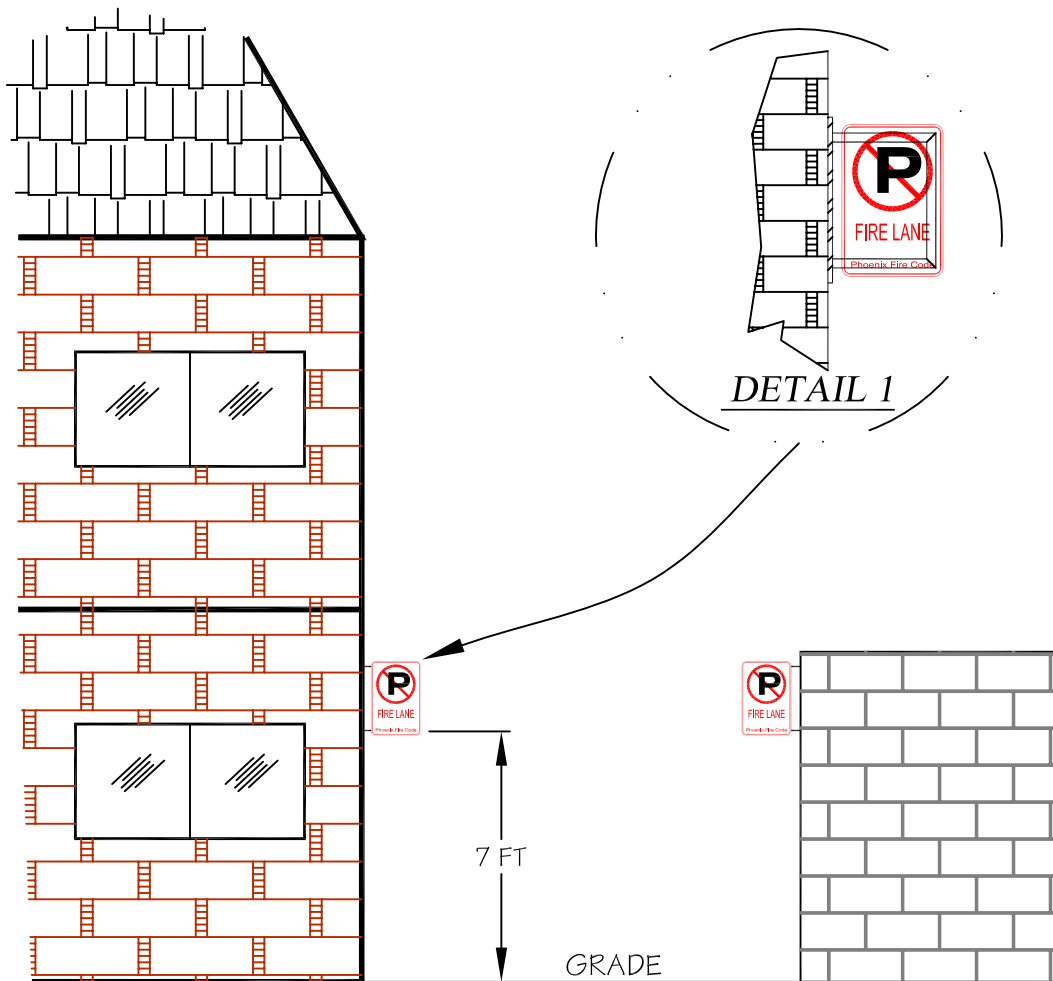

NOTES:

1. SEE DETAIL 1.7 FOR PROPER FIRE LANE PAINT STRIPING.
2. THE SAME DISTANCES FOR SIGNAGE ON POSTS ALSO APPLIES TO THE WALL MOUNTED SIGNS. FOR REQUIRED DISTANCES SEE DETAIL 1.8
3. FLAG MOUNT SIGNS MAY ONLY BE USED WHEN THERE IS NO ROOM FOR A POST.
4. MUST BE PRE-APPROVED BY FIRE PREVENTION ACCESS OFFICER.



FIRE LANE STRIPING DETAIL FOR ALONG WALLS, FENCES & BUILDINGS

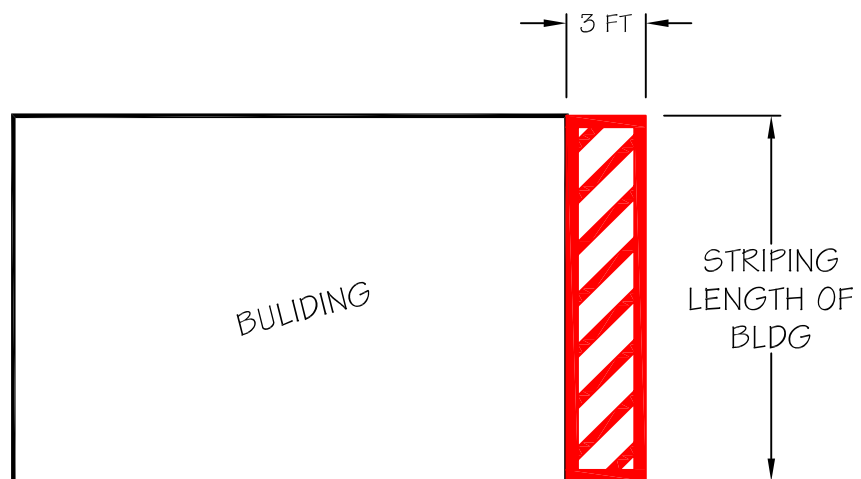
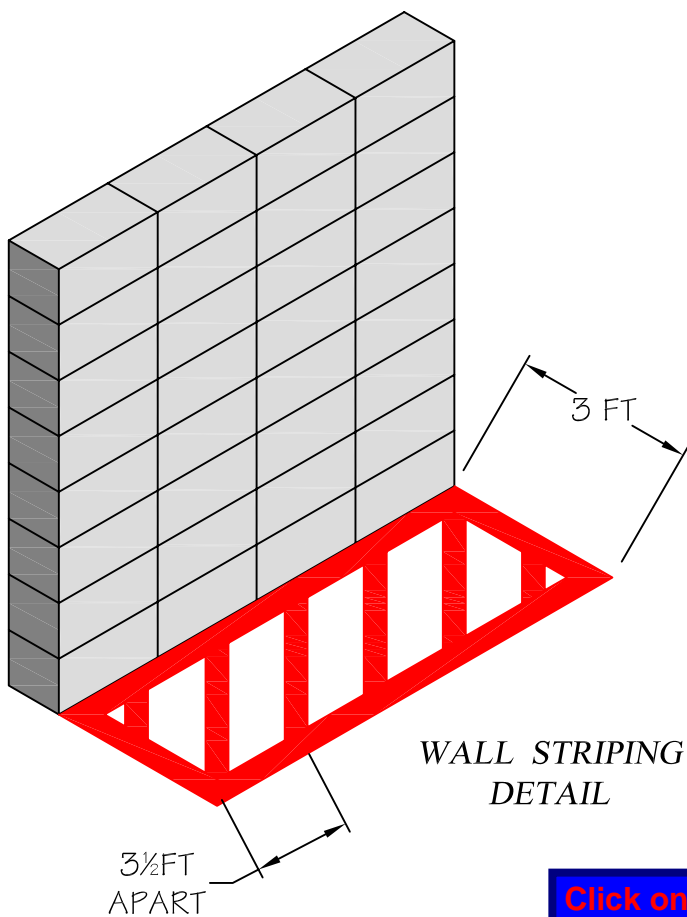

PLAN VIEW
OF BUILDING

NOTES:

1. STRIPING SHALL BE PAINTED SAFETY RED. 6 INCHES WIDE HASH STRIPING RUNNING APPROX. 4 FT. TO 6 FT. APART.
2. SEE DETAIL 1.8 FOR REQUIRED FIRE LANE SIGN PLACEMENTS.



FIRE LANE STRIPING, STENCILING AND SIGN INSTALLATION (FIGURE 5-6)

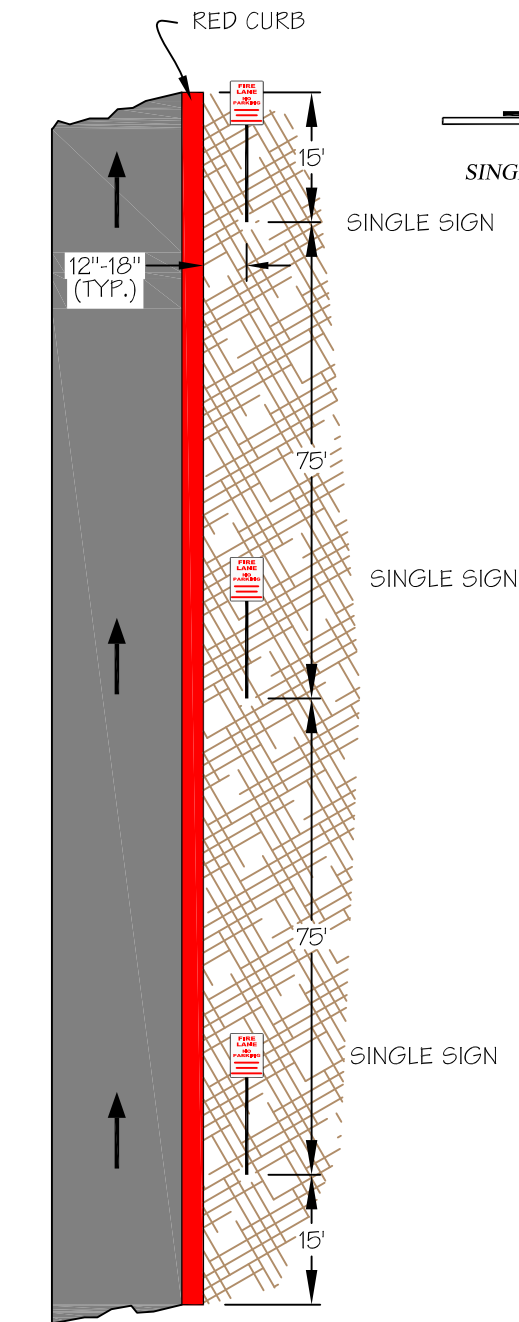

**STANDARD DETAIL 1
(WITHOUT STENCIL)**



2 APPROVED
FIRE LANE
SIGNS-BACK
TO BACK

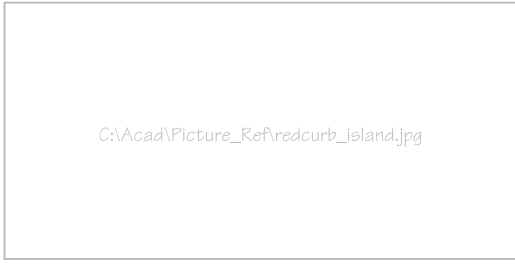
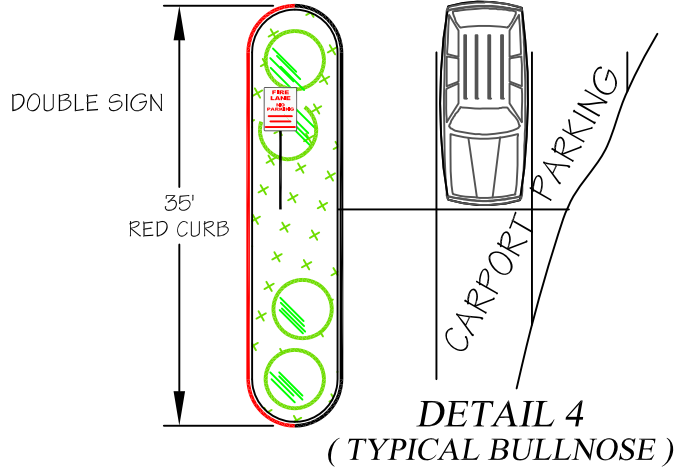

3½" X ½" WHITE LETTERING ON RED CURB
STENCIL SHALL BE CENTERED BETWEEN
SIGNS ON CURB FACE



NOTES:

1. APPROVED FIRE LANE SIGNS SHALL BE INSTALLED 12" TO 18" FROM BACK OF CURB OR BACK OF SIDEWALK.
2. SIGN MUST FACE THE ONCOMING TRAFFIC.
3. STENCILS SHALL BE IN WHITE LETTERING (3" HT. ½" STROKE) ON RED PAINTED CURB.
4. STENCIL SHALL READ "FIRE LANE NO PARKING".

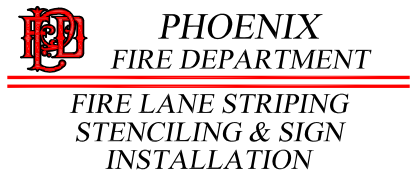

FIRE LANE STRIPING FOR HYDRANTS (FIGURE 5-12)

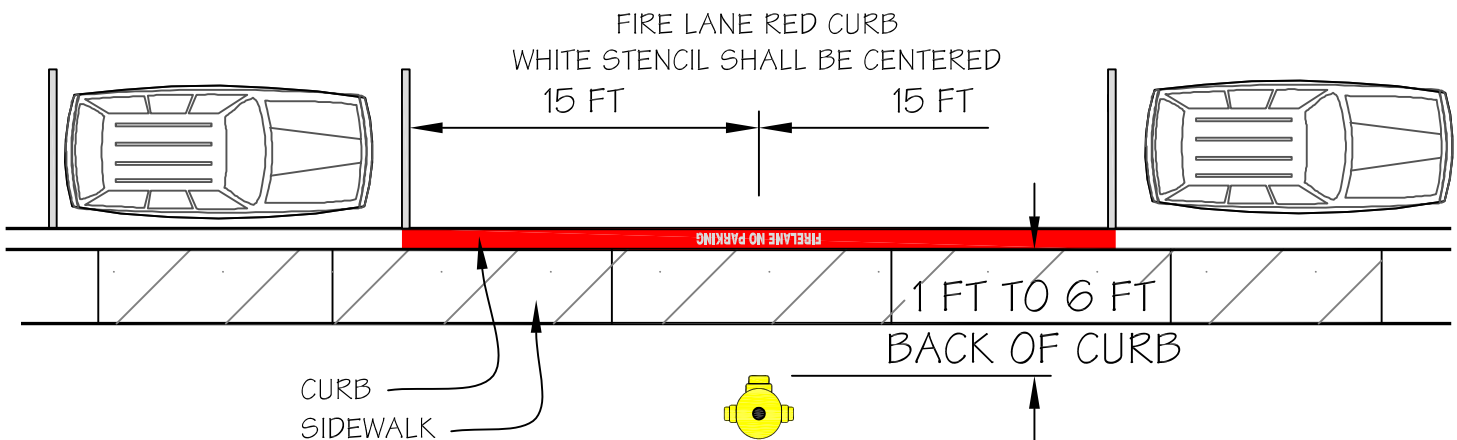
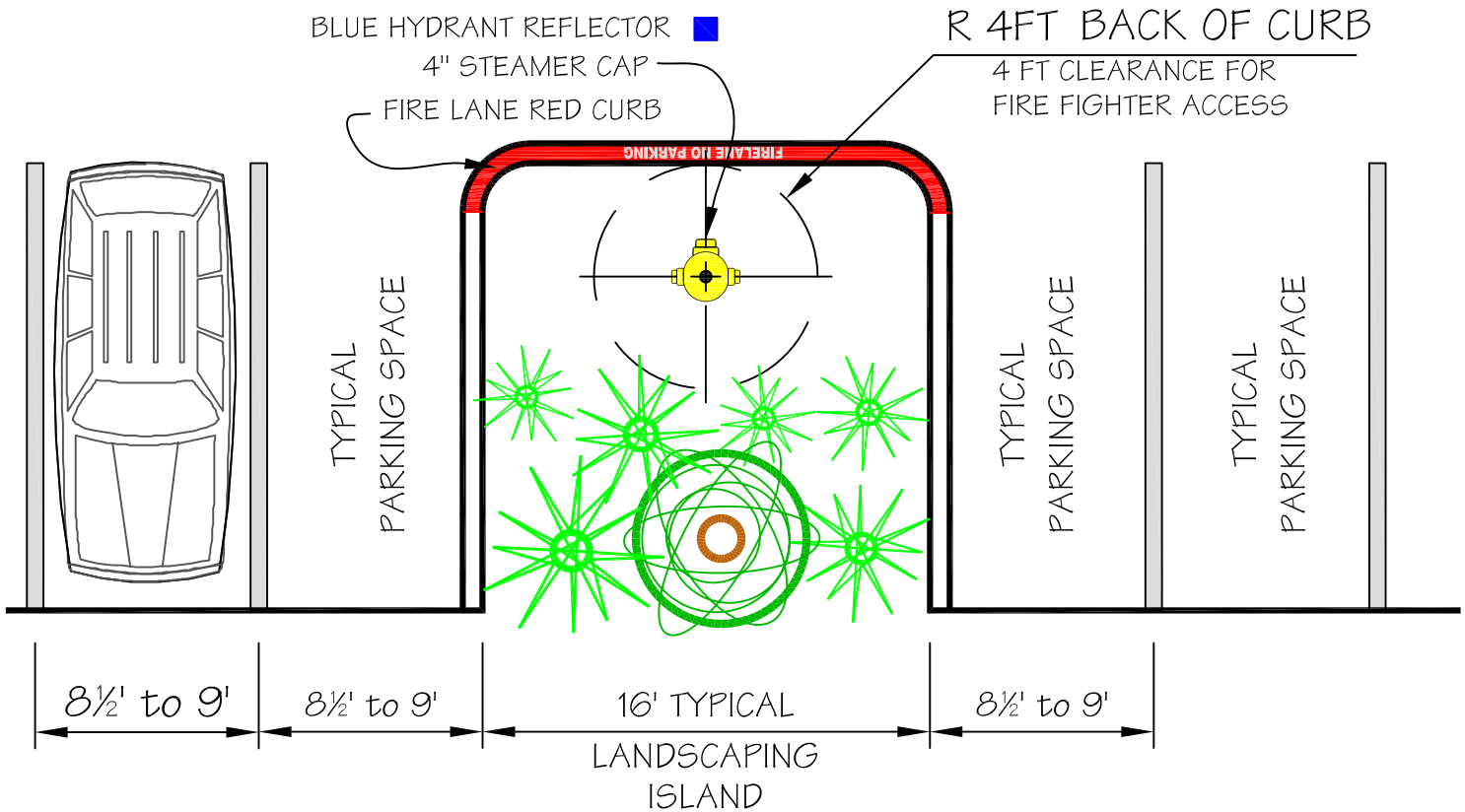

**TYPICAL PARALLEL PARKING
STREET DETAIL
FOR HYDRANT INSTALLATION**

NOTES:

- BLUE HYDRANT REFLECTOR SHALL BE PLACED 1 FT OFF OF CENTERLINE TOWARD HYDRANT SIDE.
- PUBLIC HYDRANT YELLOW
- PRIVATE HYDRANT YELLOW WITH WHITE REFLECTIVE BONNET. (SEE DETAIL 1.8B)
- OVER **100 PSI** WILL BE SIGNED HIGH PRESSURE.

Click on thumbtack for Auto CAD File

(FIGURE 5-11)

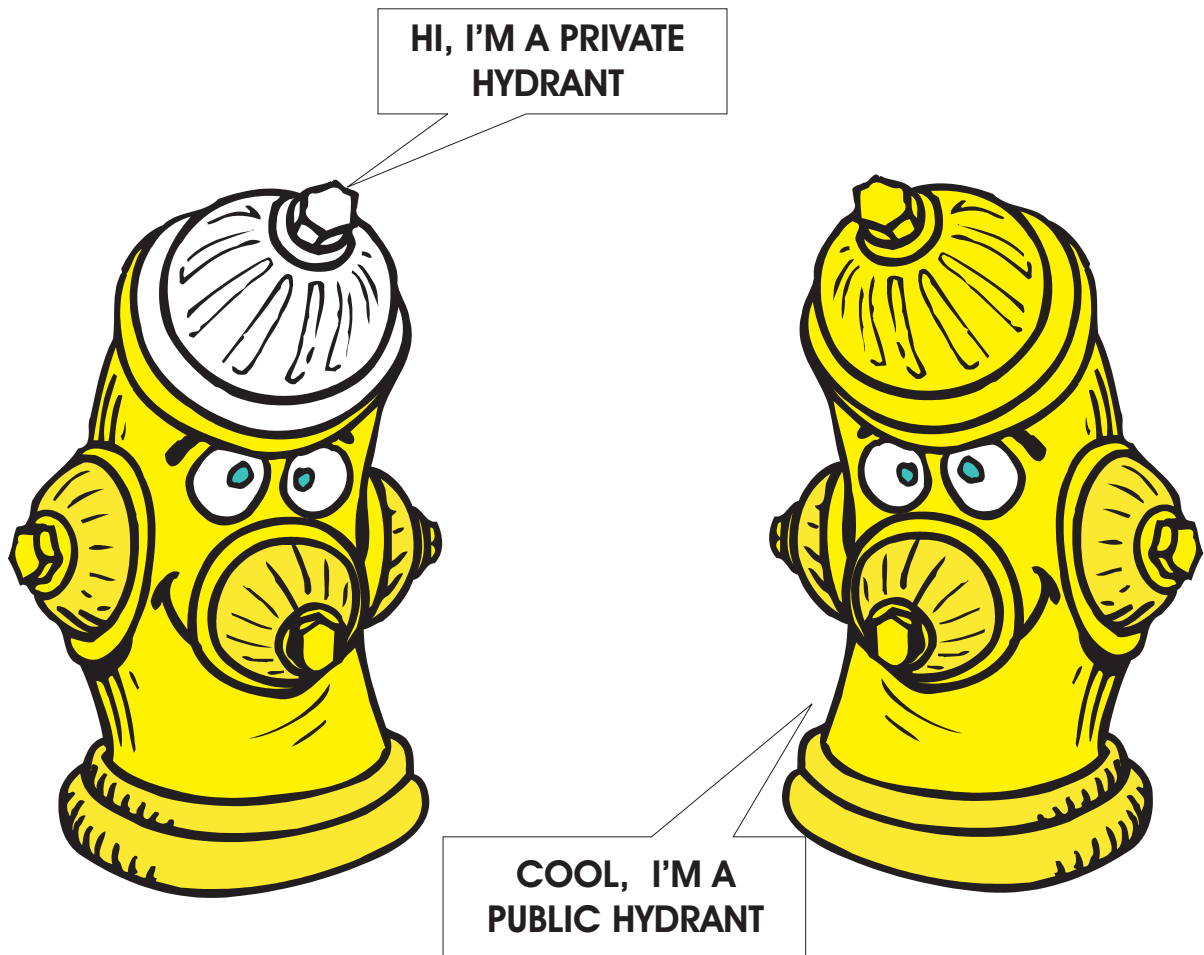

NOTES:

- PUBLIC HYDRANTS SHALL BE PAINTED WITH OSHA APPROVED FEDERAL YELLOW
- PRIVATE HYDRANTS SHALL BE PAINTED WITH OSHA APPROVED FEDERAL YELLOW AND HAVE A WHITE REFLECTIVE BONNET

Click on thumbtack for
Corel DRAW File



**PHOENIX
FIRE DEPARTMENT**

**HYDRANT COLORS
FOR PRIVATE / PUBLIC**

L. HERTZ DETAIL 1.8B MAY. 2003

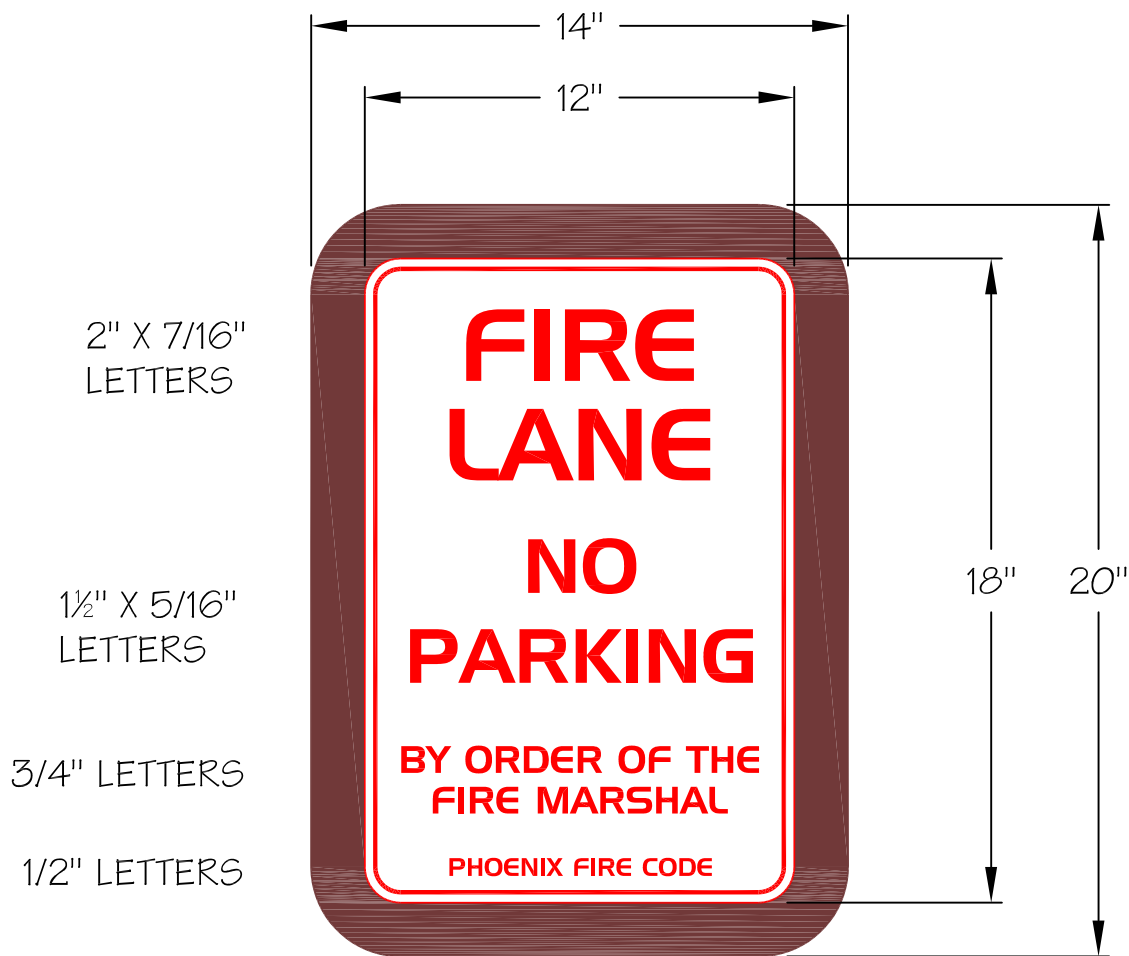

***FIRE LANE SIGN DETAIL
DESIGNER SERIES***

1. THE SIGN PLATE SHALL BE A MINIMUM OF 12" X 18" WITH A THICKNESS OF .080 ALUMINUM CONSTRUCTION
2. THE SIGN FACE SHALL HAVE A WHITE REFLECTIVE BACKGROUND WITH A RED LEGEND. USE THE STANDARD 3M SCOTCHLITE SIGN FACE NUMBER R7-32 OR EQUIVALENT, WITH RED SCREEN PRINTED LETTERING AS SHOWN ABOVE.
3. FONT STYLE USED IS HANDEL GOTHIC BT CAPITAL FONTS.
4. DECORATIVE TRIM PLATE SHALL BE 14" X 20" WITH A THICKNESS OF .080 ALUMINUM, COLOR OWNERS CHOICE.



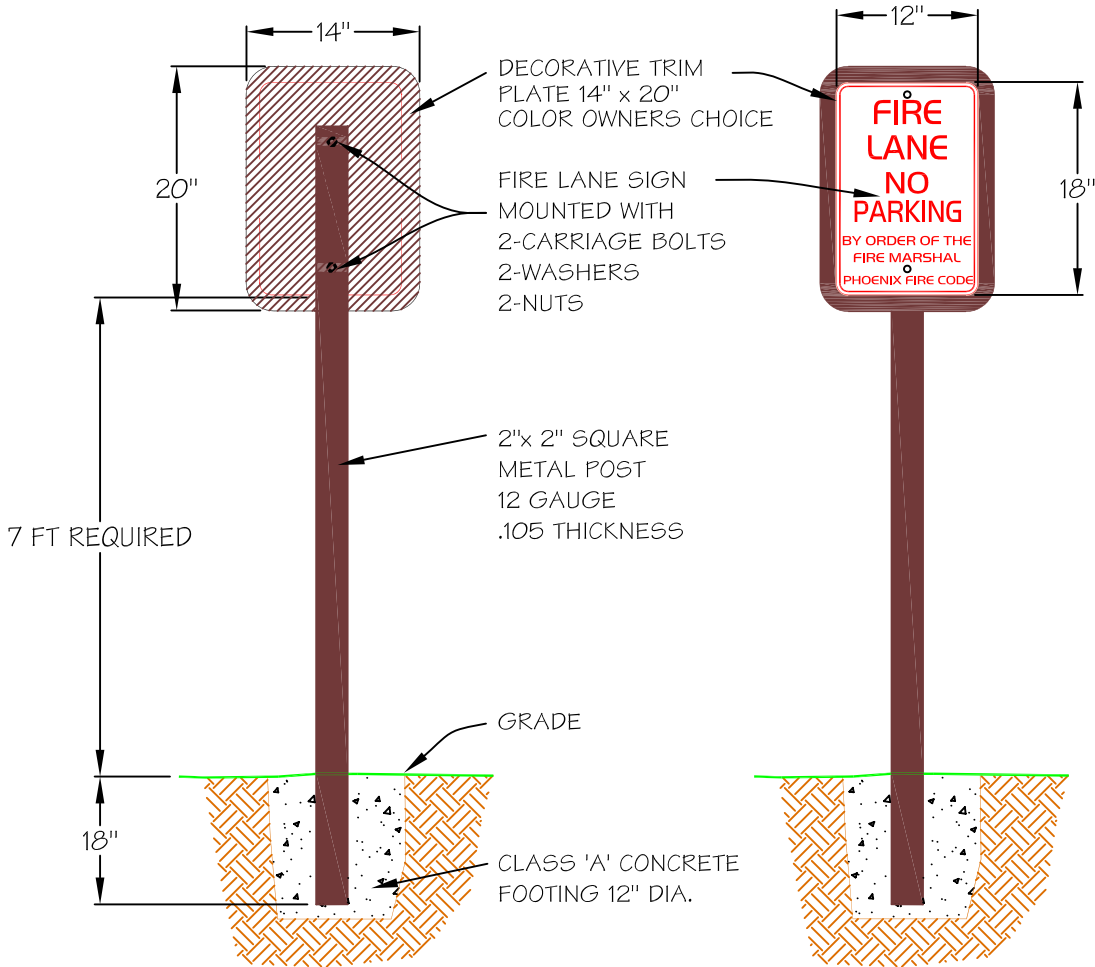
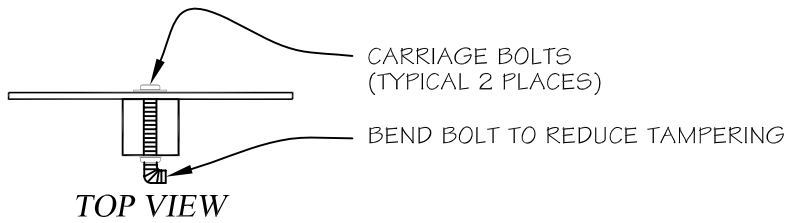

NOTES:

1. THE SIGN PLATE SHALL BE 12" X 18" WITH A THICKNESS OF .080 ALUMINUM CONSTRUCTION.
2. THE SIGN FACE SHALL HAVE A WHITE REFLECTIVE BACKGROUND WITH RED SCREEN PRINTED LEGEND.
3. LETTERS USING A HANDEL GOTHIC BT CAPITAL FONT.
4. DECORATIVE TRIM PLATE SHALL BE 14" X 20" WITH A THICKNESS OF .080 ALUMINUM, COLOR OWNER'S CHOICE.
5. 10 FT LONG PAINTED 2" X 2" SQUARE OR ROUND POST SHALL BE INSTALLED 12" TO 18" FROM BACK OF CURB OR BACK OF SIDEWALK.
6. THE SIGN SHALL BE LOCATED 7 FT FROM GRADE TO BOTTOM OF SIGN.
7. MINIMUM OF 1/4" BOLTS W/ FLAT WASHERS & NUTS THAT BOLT THROUGH POST.
8. SIGNS MUST FACE THE ONCOMING TRAFFIC.

**ARIZONA
BLUE STAKE**

CALL TWO WORKING DAYS
BEFORE YOU DIG

(602) 263-1100

1-800-STAKE-IT
(OUTSIDE MARICOPA COUNTY)

www.azbsinc.com

**Click on thumbtack for
Auto CAD File**



**PHOENIX
FIRE DEPARTMENT**

**DESIGNER FIRE LANE SIGN
POST & INSTALLATION**

SPECIAL APPLICATION DETAILS
 MUST BE PRE-APPROVED BY
 PFD-EMERGENCY ACCESS
 OFFICER AT 602-256-3382

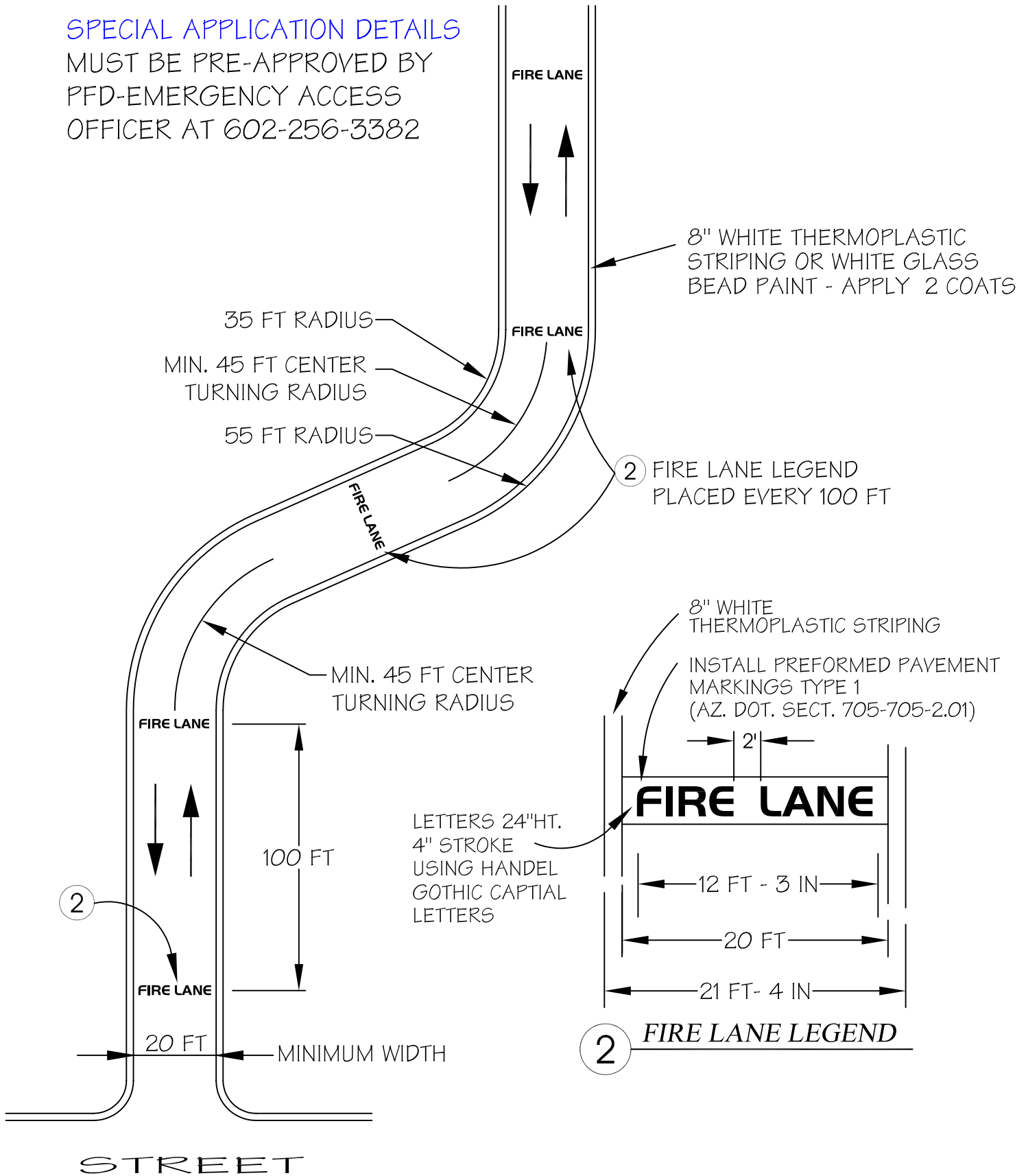

SPECIAL APPLICATION

Click on thumbtack for
 Auto CAD File



PHOENIX
 FIRE DEPARTMENT

ALTERNATIVE FIRE LANE
 MARKING SYSTEM

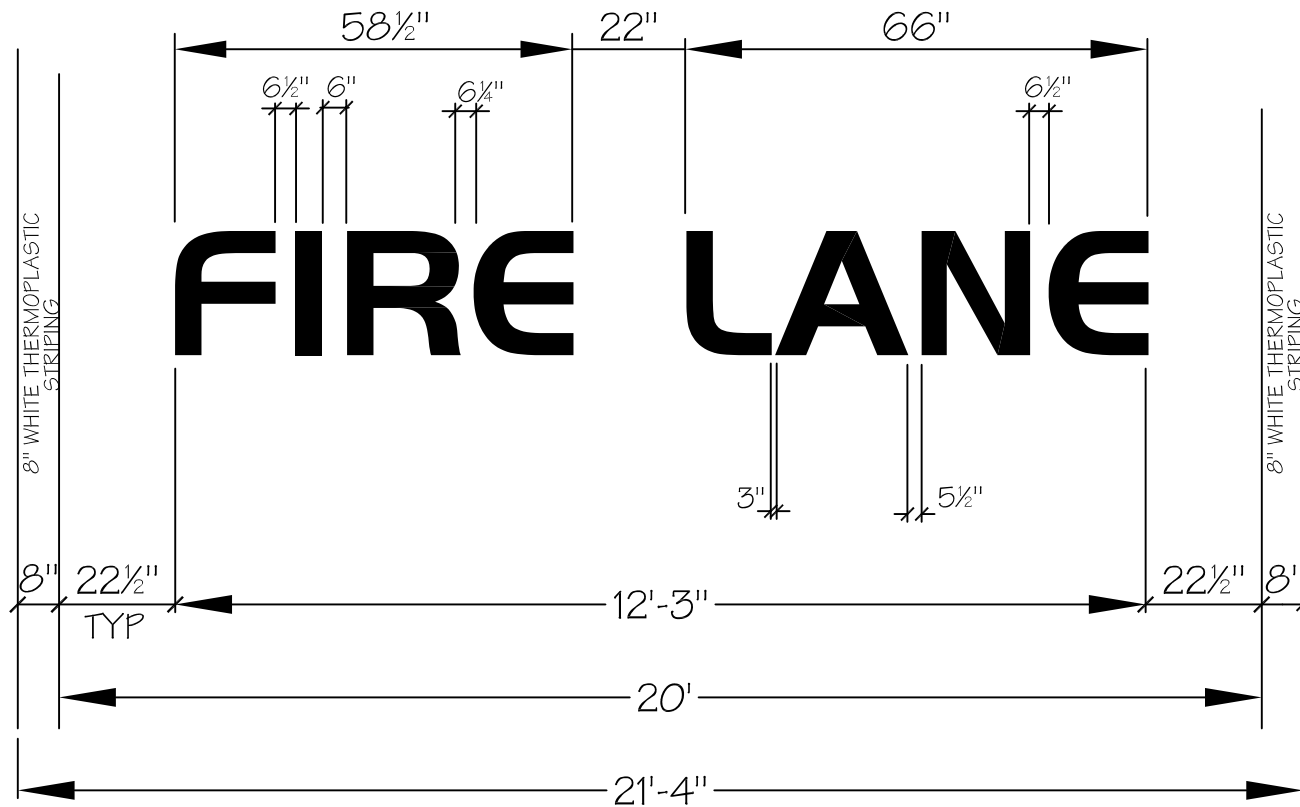

NOTES:

1. LETTERS 24" HT, 3" STROKE, USING HANDEL GOTHIC CAPITAL LETTERS.
2. INSTALL PERFORMED PAVEMENT MARKINGS TYPE 1 (AZ. DOT SECT. 705-705-2.01).
3. SPECIAL APPLICATION DETAILS MUST BE PRE-APPROVED BY PFD-EMERGENCY ACCESS OFFICER AT 602-256-3382

Click on thumbtack for Auto CAD file



SPECIAL APPLICATION

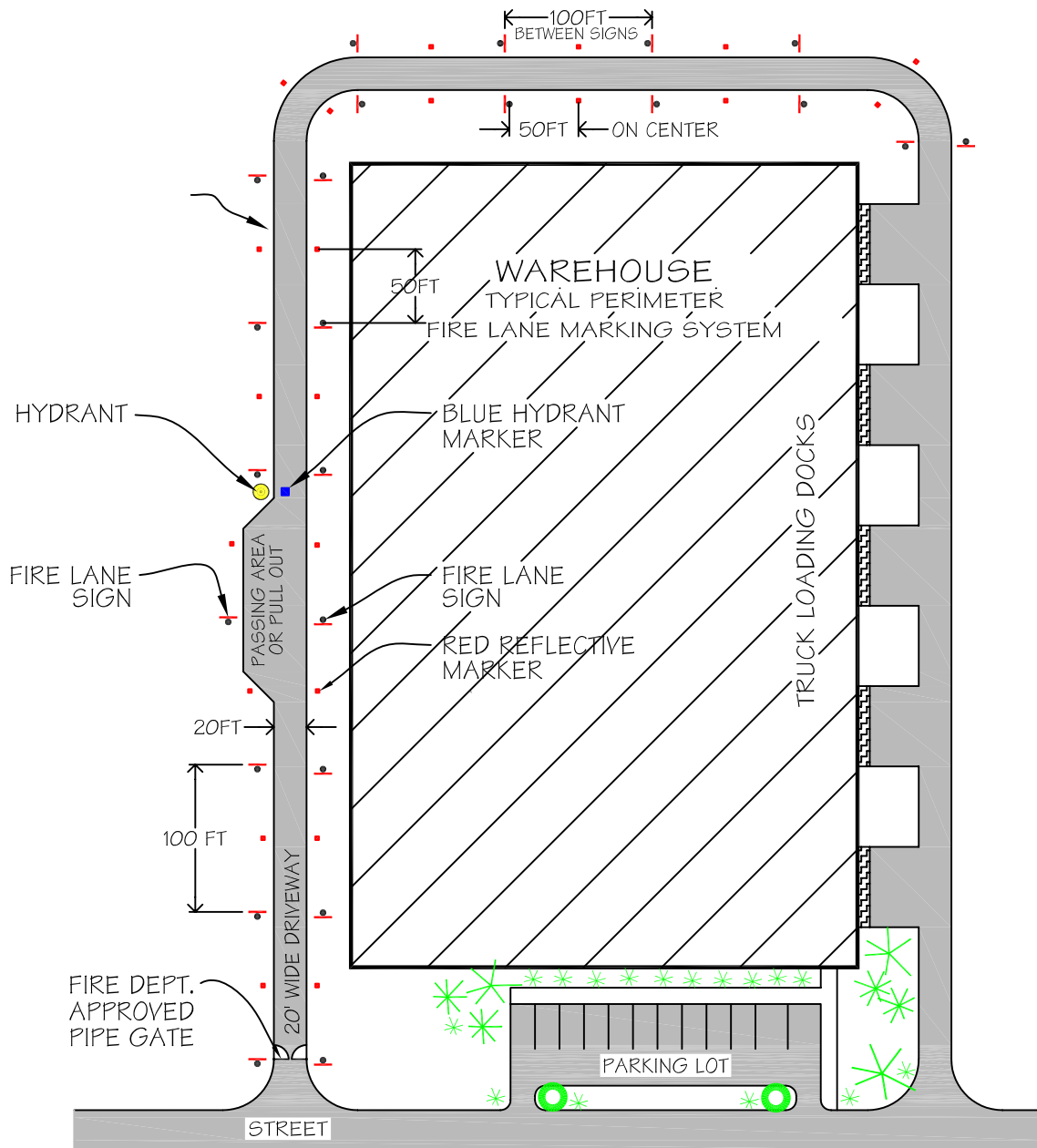

INSTALLATION INSTRUCTIONS for HARD SURFACES (Asphalt / Concrete):

3 TYPES OF ADHESIVE ARE ACCEPTABLE FOR INSTALLING RED & BLUE HYDRANT MARKERS

- A. WEDCO A-4036 EPOXY PART A RESIN
PART B CATALYST
 - B. THERMOSET EP-308 EPOXY RESIN PART 'A'
EP-308 EPOXY HARDENER PART 'B'
 - C. BITUMINOUS ADHESIVE
- NOTE: LIQUID NAILS TYPE ADHESIVE IS UNACCEPTABLE



REFLECTOR REQUIREMENTS

The adhesive shall be placed uniformly on the cleaned pavement surface in an amount sufficient to result in complete coverage of the area of contact of the markers, with no void present and with a slight excess after the markers have been placed. The markers shall be placed in position and pressure applied until firm contact is made with the pavement. The marker shall be protected against impact until the adhesive has set to the degree acceptable to the Engineer.

SPECIAL APPLICATION DETAILS MUST BE PRE-APPROVED BY PFD-EMERGENCY ACCESS OFFICER AT 602-256-3382

SPECIAL APPLICATION



**PHOENIX
FIRE DEPARTMENT**

**ALTERNATIVE FIRE LANE
MARKERING - HARDSURFACE**

L. HERTZ DETAIL 1.15 APRIL 2003



STEPS TO OBTAIN ALTERNATIVE SURFACE FIRE APPARATUS ACCESS ROAD PERMIT.

DO NOT SUBMIT 2 ENTIRE SETS OF BUILDING PLANS (see below for required pages)

- Bring **two** sets of **Alternative Surface Fire Apparatus Access Road** plans to City Hall (200 W. Washington)
 - Take the **two** sets of plans to the **Fire Plan Review Office** 10th floor
 - Complete the plan review application
-

ALTERNATIVE SURFACE FIRE APPARATUS ACCESS ROAD PLANS:

- Two sets of plans, drawn to scale
- Plan submittal shall include;
 1. Overall site plan showing location of Alternative Surface Fire Apparatus Access Roads and a dedicated page(s) depicting construction and installation specifications.
 2. Plans must depict sub-grade soil compaction, Base material quality, thickness and compaction, crown and drainage requirements, erosion protection (curbing or stabilized mesh), signage and markings.
 3. Location, including the street address, floor, and/or suite number.
 4. Submitted plans must be **wet stamped** by an Arizona registered Professional Engineer and accompanied by an Alternative Surface Fire Apparatus report
- Description of the proposed project (new build, remodel, etc.) and the business operation.
- Owners name, mailing address, contact person, and phone number optional

THE FOLLOWING ARE SPECIFIC ALTERNATIVE SURFACE FIRE APPARATUS ACCESS ROAD REQUIREMENTS:

- ❑ **Design.** Fire lanes shall be designed to support a minimum imposed live load of 66,000 pounds with a maximum axle load of 28,000 pounds.
- ❑ **Report.** Alternative surface fire apparatus access roads shall be designed by an engineer registered by the State of Arizona. The engineer shall prepare a sealed design report for submittal to and approval by the fire department. Plans shall be sealed and submitted with the report.
- ❑ **Stabilization.** Stabilization of the apparatus access road surface shall be addressed in the alternative surface fire apparatus access road report and may be accomplished by curbing.
- ❑ **Compaction.** Minimum 95% compaction of sub-grade soil is required.
- ❑ **Curbs.** A rolled curb shall be installed at the entrances to the fire apparatus access roads. (MAG details 205, 251,260-263).
- ❑ **Marking.** The curb shall be painted red or red reflectors shall be installed to define the width of the alternative surface fire apparatus access roads. The reflectors shall be imbedded into bordering curbing at intervals not exceeding 15 feet.
- ❑ **Special Inspections.** An Arizona registered Professional Engineer shall conduct a special inspection prior to final approvals being issued for alternative surface fire apparatus access roads.
- ❑ **Documentation.** The special inspection documentation shall include, but not be limited to the Following:
 1. Sub-grade soil compaction report
 2. Base material quality, thickness and compaction
 3. Concrete depth and compressive strength, when applicable
 4. An evaluation of the installation in accordance with design drawings and Manufacturer Specifications.
 5. Crown and drainage requirements
 6. Stabilization (if curbing is not used)
- ❑ Drawing must be to scale and include a graphic representation of the scale
- ❑ Drawing must be legible and dedicated to the specific item being reviewed

****Stamped approved plans, and permit must be on site for final inspection.**

INTERIOR FIRE LANE DETAIL (FIGURE 5.8)

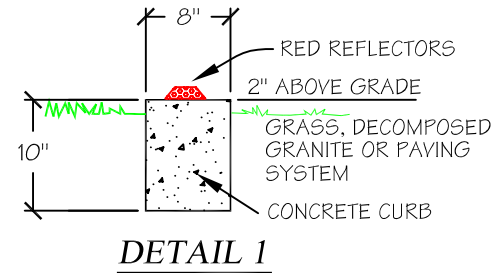
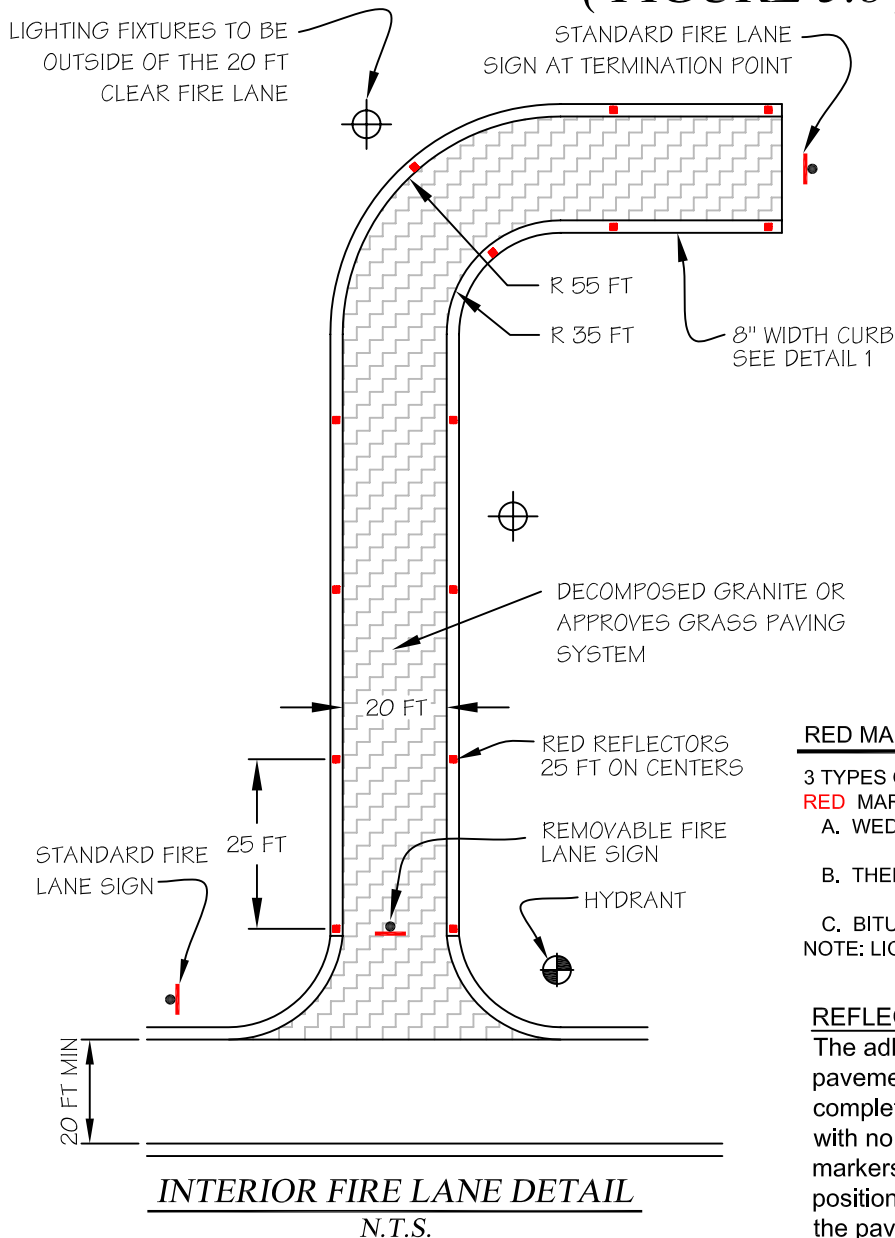

RED MARKERS INSTALLATION INSTRUCTIONS:

3 TYPES OF ADHESIVE ARE ACCEPTABLE FOR INSTALLING RED MARKERS

- WEDCO A-4036 EPOXY PART A RESIN
PART B CATALYST
- THERMOSET EP-308 EPOXY RESIN PART 'A'
EP-308 EPOXY HARDENER PART 'B'
- BITUMINOUS ADHESIVE

NOTE: LIQUID NAILS TYPE ADHESIVE IS UNACCEPTABLE

REFLECTOR REQUIREMENTS

The adhesive shall be placed uniformly on the cleaned pavement surface in an amount sufficient to result in complete coverage of the area of contact of the markers, with no void present and with a slight excess after the markers have been placed. The markers shall be placed in position and pressure applied until firm contact is made with the pavement. The marker shall be protected against impact until the adhesive has set to the degree acceptable to the Engineer.

- FIRE LANES SHALL HAVE A VERTICAL CLEARANCE OF NO LESS THAN 14 FT. AND A MIN. WIDTH OF 20 FT.
- FULL 20 FT. FIRE LANE WIDTH SHALL BE CONSTRUCTED WITH A COMBINATION OF HARD SURFACE AND PRE-ENGINEERED PLASTIC PAVER SYSTEM AS APPROVED BY THE CITY.
- FIRE LANE CAN MEANDER, BUT SHALL NOT EXCEED THE MIN. 45 FT CENTER LINE TURNING RADIUS. (35' RADIUS INSIDE / 55' RADIUS OUTSIDE)
- AREAS OUTSIDE AND BETWEEN WALKS MUST BE DECOMPOSED GRANITE OR APPROVED GRASS PAVING SYSTEM IN THE FIRE LANE AREA.
- REFER TO STANDARD ALTERNATIVE SURFACE FIRE APPARATUS ROAD STIPULATIONS PAGE AND PHOENIX FIRE CODE ARTICLE 902.7 THRU 902.7.7.

REQUIRES PERMIT

Click on thumbtack for
Auto CAD File



PHOENIX
FIRE DEPARTMENT

ALTERNATIVE SURFACE
INTERIOR FIRE LANE

L. HERTZ DETAIL 1.16 FEB. 2006

INTERIOR FIRE LANE (FIGURE 5-7)

Click on thumbtack for Auto CAD File

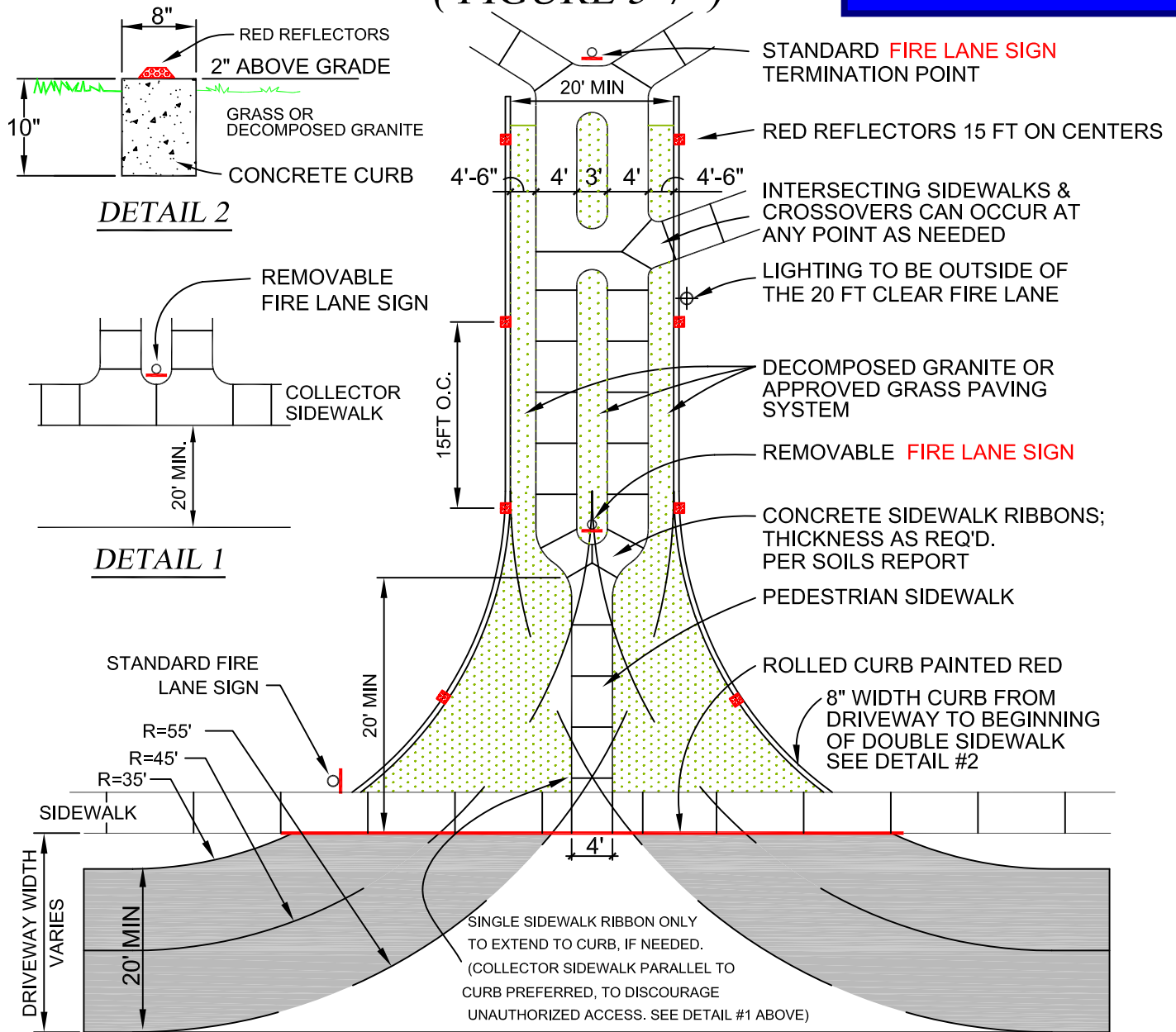

1. FIRE LANES SHALL HAVE A VERTICAL CLEARANCE OF NO LESS THAN 14 FT., AND A MIN. WIDTH OF 20 FT.
2. FULL 20 FT. FIRE LANE WIDTH SHALL BE CONSTRUCTED WITH A COMBINATION OF HARD SURFACE AND PRE-ENGINEERED PLASTIC PAVER SYSTEM AS APPROVED BY THE CITY.
3. FIRE LANE CAN MEANDER, BUT SHALL NOT EXCEED THE MIN. 45 FT CENTER LINE TURNING RADIUS. (35' RADIUS INSIDE / 55' RADIUS OUTSIDE)
4. AREAS OUTSIDE AND BETWEEN WALKS MUST BE DECOMPOSED GRANITE OR APPROVED GRASS PAVING SYSTEM IN THE FIRE LANE AREA.
5. REFER TO STANDARD ALTERNATIVE SURFACE FIRE APPARATUS ROAD STIPULATIONS PAGE AND PHOENIX FIRE CODE ARTICLE 902.7 THRU 902.7.7.
6. RED MARKERS INSTALLATION INSTRUCTIONS:

3 TYPES OF ADHESIVE ARE ACCEPTABLE FOR INSTALLING RED MARKERS

- A. WEDCO A-4036 EPOXY PART A RESIN
PART B CATALYST
- B. THERMOSET EP-308 EPOXY RESIN PART 'A'
EP-308 EPOXY HARDENER PART 'B'
- C. BITUMINOUS ADHESIVE

NOTE: LIQUID NAILS TYPE ADHESIVE IS UNACCEPTABLE

REFLECTOR REQUIREMENTS

The adhesive shall be placed uniformly on the cleaned pavement surface in an amount sufficient to result in complete coverage of the area of contact of the markers, with no void present and with a slight excess after the markers have been placed. The markers shall be placed in position and pressure applied until firm contact is made with the pavement. The marker shall be protected against impact until the adhesive has set to the degree acceptable to the Engineer.

REQUIRES PERMIT



PHOENIX
FIRE DEPARTMENT

INTERIOR FIRE LANE

L. HERTZ DETAIL 1.17 APRIL 2003

REMOVABLE FIRE LANE BOLLARD

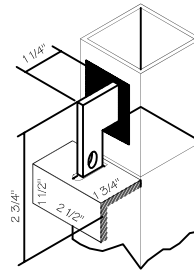
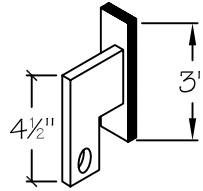
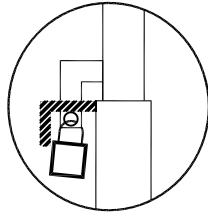

LOCKING DETAIL

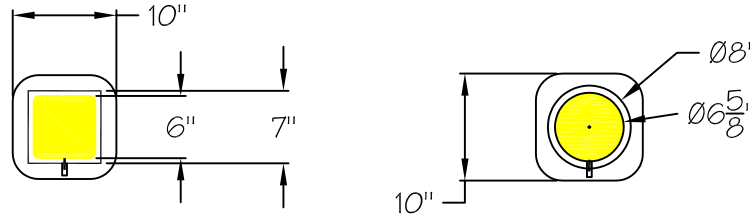

PLAN VIEW

6" SQUARE TUBE X 4' - 10" L
3/16" WALL BOLLARD

BOLLARDS SHALL BE PAINTED
CHROME YELLOW

BOLLARD SHALL BE
6" DIA. INSIDE X
6 5/8" DIA. OUTSIDE
SCHEDULE 40 PIPE



2" X 4" SLOTTED
HAND HOLE
BOTH SIDES

2" WIDE STEEL
COLLAR WITH
CUT OUT FOR
LOCKING L - BRACKET

SLEEVE PIPE SHALL BE
6 7/8" DIA INSIDE X
8" DIA OUTSIDE
SCHEDULE 160 PIPE

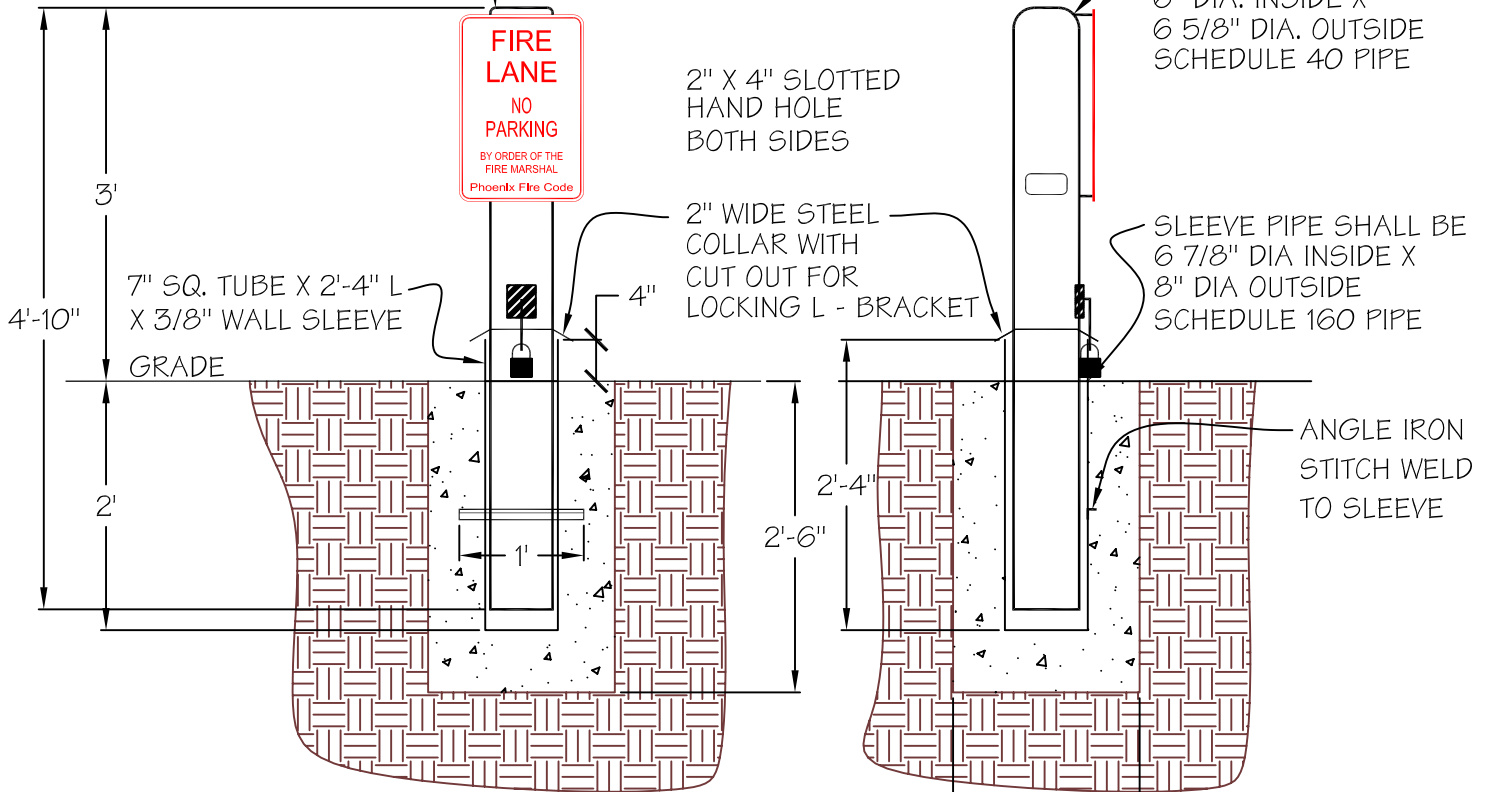

ELEVATION VIEW

SQUARE
BOLLARD

ROUND
BOLLARD



Click on thumbtack for
Auto CAD File



PHOENIX
FIRE DEPARTMENT

REMOVABLE BOLLARD
ROUND OR SQUARE

L. HERTZ DETAIL 1.18 JUNE 2003

FILE NAME: PIPE_BOLLARD.dwg
CALL FIRE PREVENTION-ACCESS OFFICER
FOR QUESTIONS OR ASSISTANCE
602-256-3382 OR 602-262-6771

REMOVABLE FIRE LANE SIGN

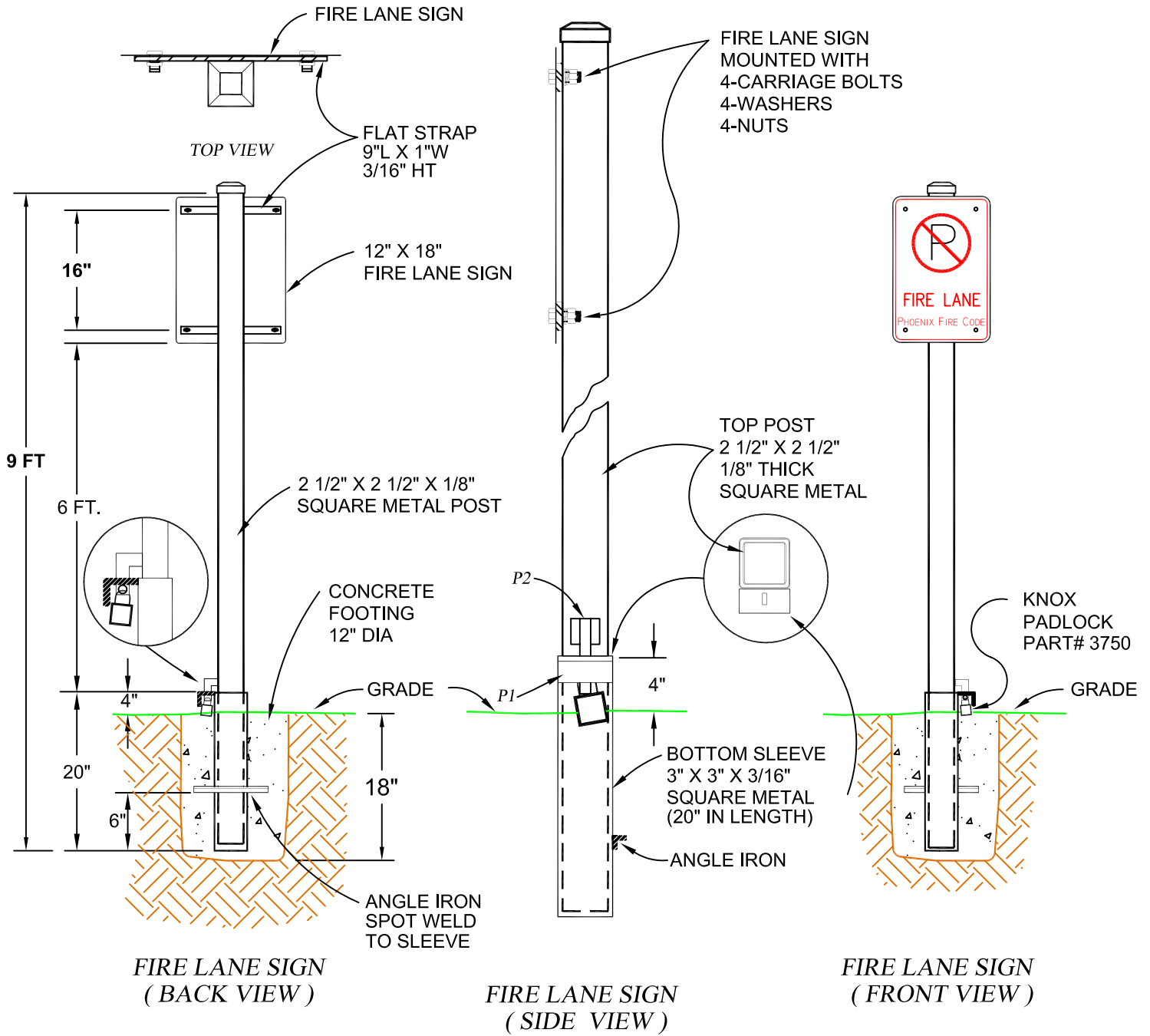

FILE NAME: Removfs.dwg
 CALL FIRE PREVENTION-ACCESS OFFICER FOR QUESTIONS OR ASSISTANCE
 602-256-3382 OR 602-262-6771

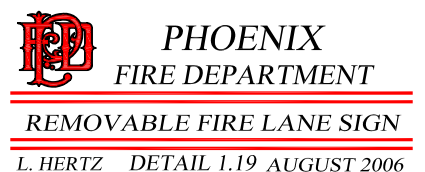

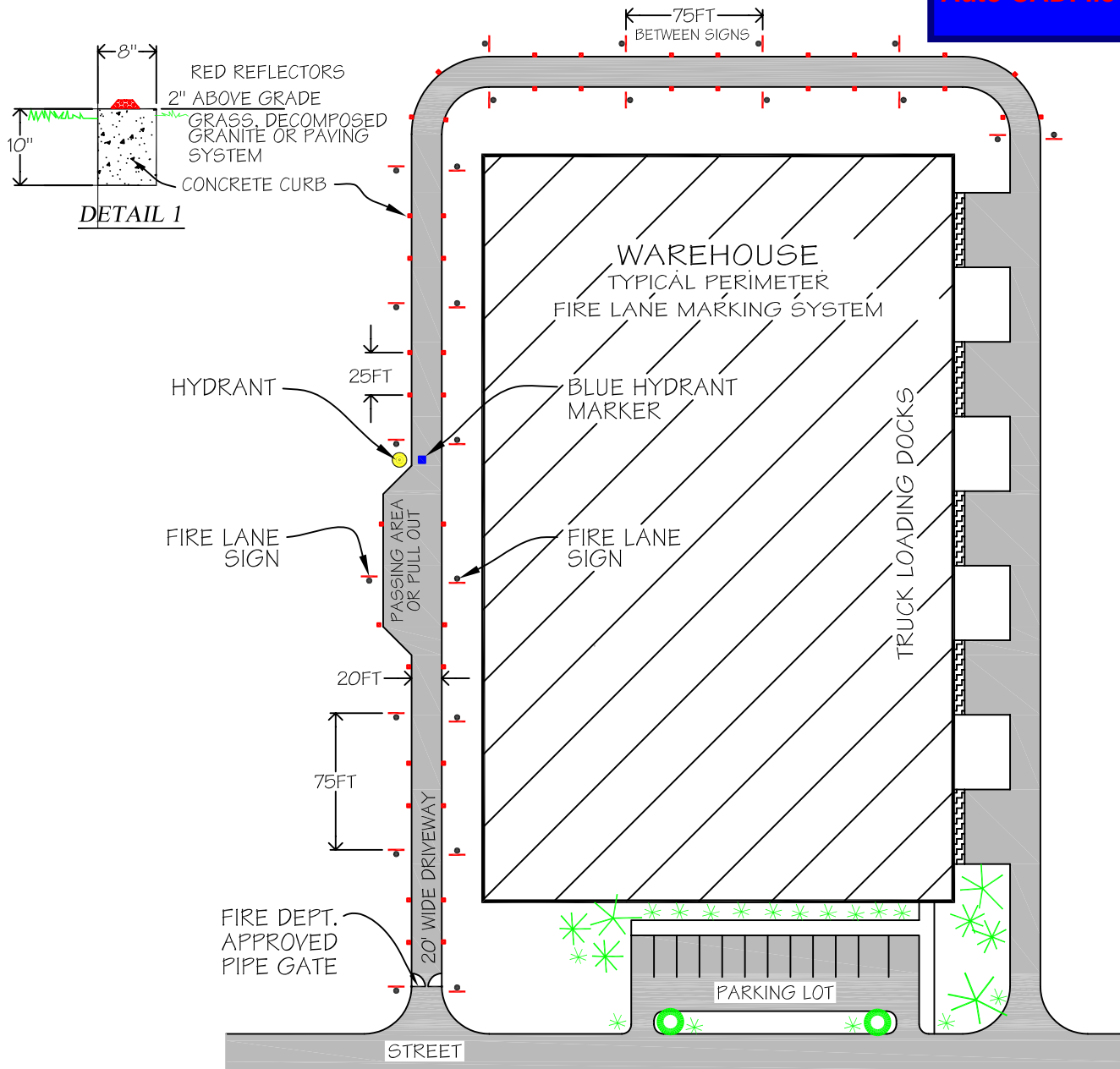

INSTALLATION INSTRUCTIONS for SOFT SURFACES (Decomposed Granite/ABC):

3 TYPES OF ADHESIVE ARE ACCEPTABLE FOR INSTALLING RED & BLUE HYDRANT MARKERS

- A. WEDCO A-4036 EPOXY PART A RESIN
PART B CATALYST
- B. THERMOSET EP-308 EPOXY RESIN PART 'A'
EP-308 EPOXY HARDENER PART 'B'
- C. BITUMINOUS ADHESIVE

SEE STANDARD ALTERNATIVE SURFACE FIRE APPARATUS ROAD STIPULATIONS, PFC 902.7. THRU 902.7.7

NOTE: LIQUID NAILS TYPE ADHESIVE IS UNACCEPTABLE

REFLECTOR REQUIREMENTS

The adhesive shall be placed uniformly on the cleaned pavement surface in an amount sufficient to result in complete coverage of the area of contact of the markers, with no void present and with a slight excess after the markers have been placed. The markers shall be placed in position and pressure applied until firm contact is made with the pavement. The marker shall be protected against impact until the adhesive has set to the degree acceptable to the Engineer.

SPECIAL APPLICATION DETAILS MUST BE PRE-APPROVED BY PFD-EMERGENCY ACCESS OFFICER AT 602-256-3382

**SPECIAL APPLICATION
REQUIRES PERMIT**



**PHOENIX
FIRE DEPARTMENT**

**ALTERNATIVE SURFACE
FIRE LANE MARKING - SOFT SURFACE**

L. HERTZ DETAIL 1.21 APRIL 2003



FNAME: DP1_2.CDR
CALL FIRE PREVENTION-ACCESS OFFICER
FOR QUESTIONS OR ASSISTANCE
(602)256-3382 OR (602)262-6771

Click on thumbtack for
Corel DRAW File 



**PHOENIX
FIRE DEPARTMENT**

**ALTERNATIVE SURFACE
FIRE LANE**

L. HERTZ DP 1.2 MAY. 2003